



GS1 Bar Code Verification
For Linear Symbols
Version 4.3, May 2009

Document Summary

Document Item	Current Value
Document Title	GS1 Bar Code VerificationFor Linear Symbols
Date Last Modified	May 2009
Current Document Issue	Version 4.3
Status	Final
Document Description (one sentence summary)	Technical overview for applying ISO verification to GS1 linear symbols.

Contributors

Name	Organization
See "GS1 Bar Code Verification Best Practice" work team	GS1

Log of Changes in Version 4.3

Issue No.	Date of Change	Changed By	Summary of Change
Version 4.3	May 2009	Wilson Silva Lutfi ilteris Oney	Terms Update in line with the GS1 General Specifications January 2009 release. New Test Card pictures

Publication History	
Original	August 2000
Version 2.0	January 2003
Version 2.1	July 2003
Version 2.1-1	March 2004
Version 3.0	February 2006
Version 3.1	March 2006
Version 4.0	November 2006
Version 4.1	February 2007
Version 4.2	February 2009
Version 4.3	May 2009

Disclaimer

Whilst every effort has been made to ensure that the guidelines to use the GS1 standards contained in the document are correct, GS1 and any other party involved in the creation of the document HEREBY STATE that the document is provided without warranty, either expressed or implied, of accuracy or

- fitness for purpose, AND HEREBY DISCLAIM any liability, direct or indirect, for damages or loss relating to the use of the document. The
- document may be modified, subject to developments in technology, changes to the
- standards, or new legal requirements. Several products and company names mentioned herein may be trademarks and/or registered trademarks of their respective companies.

Table of Contents

1. Foreword	6
2. Introduction.....	7
3. What is verification for?	8
3.1. Is verification the only way of achieving good quality symbols?	8
3.2. What is a verifier? How does it differ from a scanner?.....	8
3.3. Why not just use a scanner to check readability?	9
3.4. Who needs to use verification?	9
3.5. Benefits.....	9
4. Verification techniques and history.....	10
4.1. Principal methodologies	10
4.2. Traditional verification.....	10
4.3. ISO verification	11
4.4. Equipment conformance standards.....	12
4.5. History of adoption in the GS1 General Specifications	12
5. What verification does – and its limitations.....	14
6. When to verify.....	15
6.1. In symbol production	15
6.1.1. At the design stage	15
6.1.2. Film master/electronic origination/volume printing	15
6.1.3. On-demand printing	16
6.2. Post manufacture (finished goods despatch/receipt).....	17
7. How to use a verifier.....	18
7.1. Importance of calibration	18
7.1.1. Calibration Frequency.....	18
7.1.2. Calibration materials	19
7.1.3. Calibrated Conformance Standard Test Card	19
7.2. Selection of aperture/light source.....	19
7.3. Scanning the symbol	20
7.3.1. Hand-scanned verifiers.....	20
7.3.2. Automatically scanned verifiers	22
7.4. What additional steps need to be taken (e.g. visual inspection)?	22
8. Scan reflectance profile analysis.....	23
8.1. What is a scan reflectance profile?	23
8.2. Pre-conditions for obtaining the profile (lighting, aperture)	23
8.3. Analysis of the profile and symbol grading.....	26
8.4. Parameters measured and their significance.....	29
8.4.1. Decode.....	29
8.4.2. Symbol Contrast (SC).....	29
8.4.3. Minimum reflectance (R_{\min}).....	30

8.4.4.	Edge contrast (EC)	31
8.4.5.	Modulation (MOD)	31
8.4.6.	Defects.....	31
8.4.7.	Decodability	32
8.4.8.	Bar width deviation (non-graded)	32
9.	Interpreting the results.....	33
10.	Potential causes of less-than-perfect grades	34
10.1.	By parameters	34
10.1.1.	Reflectance parameters.....	34
10.1.2.	Other parameters.....	35
10.2.	By printing types	39
10.2.1.	Contrast in general	39
10.2.2.	Measurements in general	40
10.2.3.	Defects in general.....	40
10.2.4.	Decode in general.....	40
10.2.5.	Bar codes that fail to decode (general).....	41
10.2.6.	Thermal printing.....	41
10.2.7.	Laser printer.....	42
10.2.8.	Ink Jet printing	42
10.2.9.	Impact printing	42
10.2.10.	High printing (book printing, flexography etc.).....	43
10.2.11.	Engraved printing (rotograue).....	43
10.2.12.	Offset printing	43
10.3.	By surface types	43
10.3.1.	Corrugated board.....	43
10.3.2.	Labels with metal	44
10.3.3.	Film (foil).....	44
10.3.4.	Metals (cans)	44
10.3.5.	Metal films with engraving	44
10.3.6.	Non-opaque substrates	44
10.3.7.	Glossy substrates	45
11.	Using traditional measurements as part of quality	46
11.1.	Print Contrast Signal and tolerances.....	46
11.2.	Supplementing scan reflectance profile parameter grading with traditional measurements.....	46
12.	Considerations for GS1 System symbologies	47
12.1.	Symbologies used in the GS1 System.....	47
12.1.1.	EAN/UPC Symbology	47
12.1.2.	GS1-128 Symbology.....	48
12.1.3.	ITF-14 Symbols	49
12.1.4.	GS1 DataBar	50
12.1.5.	Other GS1 Symbologies.....	50
ANNEX A.	Grade thresholds for scan reflectance parameters.....	52
ANNEX B.	Use of Calibrated Conformance Standard Test Card.....	53



ANNEX C.	The process of symbol generation	55
ANNEX D.	GS1 Bar Code Verification Template	59
ANNEX E.	Selecting a Verifier	62
ANNEX F.	Glossary of terms	65

1. Foreword

This GS1 Global Office publication has been developed with the intention of providing a clear explanation on the practical implications of Bar Code Verification within the GS1 System. Although the target audience is GS1 Member Organisation staff involved in Bar Code Verification, it is hoped that the information contained will be of use as a basis for training and/or reference material for specialists or end users involved in Bar Code production and print quality. It is intended as a guide and it does not replace the *GS1 General Specifications* which remains the repository for all GS1 Technical Specifications related to Bar Code.

GS1 Global Office acknowledges the work of Chris Swindin in preparing the original draft of this publication as well as the improvements and additions made by Peter Regős.

The current release introduces the new test card templates and incorporates the GS1 naming conventions. GS1 Global Office expresses its thanks to all those individuals, too numerous to list, who have provided input to this publication.

2. Introduction

This booklet has been prepared to help GS1 Member Organisations answer the more common questions about the role, use and interpretation of bar code verification and its results. It concentrates on the application of the "scan reflectance profile" assessment methodology (now known as "ISO verification" or "ISO/IEC 15416 method") as defined in International Standards and on its use for bar code verification in the GS1 System.

The international standard definition of verification: *The technical process by which a bar code is measured to determine its conformance with the specification for that symbol* – first and foremost with the symbology specification, and secondly with any additional specifications, such as those relating to the scanning application in which the bar code is being used, which may modify or restrict the range of symbology parameters.

Examples of such specifications are the symbology specification for Code 128 (ISO/IEC 15417) which defines how a Code 128 symbol is constructed and how data is represented in it, and the additional specification laid down by GS1 for GS1-128 symbols, which defines the specific format for the use of Code 128 in the GS1 System, dimensional limits, and the structure of the data content.

Verification of a GS1-128 symbol, therefore, requires checking that the symbol structure is correct according to the symbology specification, that it is dimensionally consistent with the requirements of the *GS1 General Specifications* – including the correct use of the FNC1 symbol character and, possibly, the correct use of the GS1 Company Prefix. In addition, verification of any symbol involves ensuring that the amounts of light of the specified colour reflected by the bars and spaces respectively are sufficiently distinct to enable the symbol to be correctly recognised by a scanning system.

3. What is verification for?

A bar code's primary function is that of carrying data from the point at which it is originated to the point at which the data has to be captured. So the bar code is a vital link in the data communication chain of any application. If it fails, the chain breaks. A bar code which does not scan often causes more problems to trading partners than no symbol at all. Verification of bar codes is, therefore, a useful tool to add to quality control procedures in order to ensure that the bar codes will scan correctly throughout the supply chain.

Verification aims to check that the symbol is able to fulfil its function, by performing two principal tasks:

- Enabling the symbol producer to measure his output and to apply feedback in order to control his process;
- Predicting the scanning performance likely to be achieved by a symbol.

It is important to note that only a sample of symbols in any batch or production run will normally be verified, and 100% sampling is neither expected nor necessary, because of the relatively consistent quality levels achieved by the production processes usually used for bar codes. Ideally, the sampling basis will be determined by the statistical procedures used for the organisation's Quality Control programme.

Verification then assists the symbol producer and receiver in setting an agreed quality level for acceptance, allowing them to agree on the acceptability or otherwise of a given symbol.

Verification carries these tasks out by measuring how close the symbol is to "perfect" in relation to both the symbology specification and certain attributes which are related to the printing or reading of the symbol, and by reporting a quality grade which correlates with the likely scanning performance of the symbol.

3.1. Is verification the only way of achieving good quality symbols?

It has to be recognised that the symbol can only be verified after it has been produced and so verification cannot be used to improve the symbol that is being verified, only later ones. It is not the only way in which the production of reliably performing symbols can be assured. A perfectly acceptable output which is unlikely to give scanning problems can be achieved by following well-managed printability testing procedures, representative of the expected production conditions, using properly specified test patterns or Bar Gain Gauges – particularly where symbols are to be originated from film masters. These enable the effect of the reproduction and printing processes on the symbol to be evaluated, in terms of bar width gain (or loss) and the range over which it varies, in order to determine the compensating allowances which need to be built in to the film master or other original bar code. The *GS1 General Specifications* make express provision for this approach. But even here a verifier can be of use in providing the measurements needed to evaluate the test results. Some Verifiers allow also Film Master Verification (according ISO/IEC 15421).

3.2. What is a verifier? How does it differ from a scanner?

A verifier is a precision measuring instrument designed to provide consistent and repeatable measurements of a symbol and to analyse these measurements in relation to the likely scanning performance of the symbol under a range of conditions. It has to be calibrated before use and be controlled regularly to maximise the repeatability and consistency of its measurements.

A bar code scanner simply decodes the pattern of bars and spaces into the data encoded in the symbol. It does not measure any of the parameters that affect how a bar code can be decoded.

3.3. Why not just use a scanner to check readability?

No two bar code readers are the same. The optical arrangements available for scanners vary widely, ranging from light pens or wands to CCD scanners and hand-held or omnidirectional laser scanners and from manually-operated to automatic, unattended devices, any of which might be found at the various points in the distribution chain to the retail store or warehouse through which the product passes. Inevitably, these show quite noticeable differences in their scanning performance. Also, in order to maximise their performance, manufacturers of bar code readers build all kinds of clever features into their decode algorithms to help the equipment decode even poor quality symbols, reliably and as rapidly as possible. However, not all of these works in the same way and two different readers might well have different degrees of success with the same symbol.

So test scanning a symbol with, for example, a wand reader will not give any reliable indication of whether it would read with a laser scanner, nor even that any other wand reader could read it successfully. Nor does it help you understand whether the symbol deviates from perfect and if so what is wrong with it. At best, it can be used as a "go/no-go" test of whether a symbol can be read by that scanner (only), and to check the data content; it is risky to extrapolate any wider conclusions. But a verifier bases its assessment on the use of a standardised reference decode algorithm specified as part of the symbology specification, and on calibration of its optical response. Both of these enable consistent and objective quality assessments to be made irrespective of what type of scanner will be used in the application.

3.4. Who needs to use verification?

Anyone who is handling bar codes and who has an interest in their performance has a potential need for verification. The main classes of user are:

- The printer of the symbols (this might be a packaging manufacturer, or the product manufacturer if he uses an on-demand printing system), for quality assurance and process control purposes;
- The party on whose product or item that the bar code is being applied (the brand owner), for assurance that his customers will accept the symbols;
- The party receiving the bar coded item, for assurance that the symbols will work satisfactorily in his operation;
- The party handling the goods at intermediate stages of the supply chain, who may wish to assure themselves of the symbol quality for similar reasons.

It is the responsibility of the bar code 'originator' (usually the brand owner of the product being bar coded) to ensure that it meets the quality requirements of the entire supply chain.

3.5. Benefits

The biggest benefits of verification are, simply, reassurance and confidence that the bar code will perform as intended at all stages of the product's passage down the supply chain, leading to untroubled supplier-customer relationships.

Additional benefits accrue to the symbol producer, who is able to make use of the measurement information on the symbols he is producing to monitor his production process and adjust his equipment or procedures in order to correct any deviations from his optimum quality. Package designers can use feedback from verification to make sure that symbol size, position and colour will not result in point-of-use difficulties.

The receiver of bar coded products, too, reaps advantage from verification of incoming bar codes, to assess the likelihood of their causing him scanning problems in his handling and inventory control systems, or at the point of use.

4. Verification techniques and history

The theory and practice of verification have evolved enormously in the nearly thirty years since bar code technology was first introduced into the retail world, along with the means of creating bar codes. Verifiers, as purpose-designed instruments, first appeared on the scene in the mid-70s; prior to that, the different components of verification were performed with devices designed for other purposes.

4.1. Principal methodologies

There are four methods which are or have been in common use for the quality assurance of bar codes, or at least for the goal of ensuring adequately scannable symbols at the point of use. These are:

- Bar width measurement by microscope before developing special verification methods
- Printability test-based procedures, as described earlier (these are not "verification" as such);
- Traditional verification;
- Scan reflectance profile analysis, more commonly known as "ISO verification."

4.2. Traditional verification

Traditional verification methods were introduced in the early to mid 1970s and were based on the measurement of two symbol parameters, namely print contrast signal (PCS) and the bar width deviation. If the bar (or space) widths were within a defined (but somewhat arbitrary) tolerance and if PCS was above a defined minimum value, the symbol was regarded as "in spec."

Initially, none of these measurements was automated and human factors affected the accuracy and repeatability of measurements. Also, checking that the symbol was correctly encoded was a laborious task. However, within a few years instruments were developed which performed these measurements automatically. These were the first true verifiers that enabled the printer to take steps to produce the symbols as nearly perfectly as his process allowed.

However, one of the difficulties in connection with traditional verification was that the methodology, although generally understood, was never standardised in detail, which was the primary reason for differences in verification results on the same symbol. From a technical viewpoint, the two areas that should have been standardised to enable more consistent traditional measurements to be made were the edge location threshold point and the points at which the light and dark reflectance values used for calculating PCS were measured. Since they were not standardised, different verifier manufacturers measured these in different ways. This was a recipe for commercial disputes between suppliers and their customers, since it was not uncommon, when the symbols were measured by the different parties, for the customer to say "My verifier says these symbols are out of specification" while his supplier maintained "But they were in specification when I verified them!" Since a rejection usually means the return of a whole consignment of goods and often a fine, the financial consequences are severe.

Another factor against traditional verification is the fact that the assessment of the symbol gives only a single threshold for acceptability – "In spec." or "Out of spec.". Also, typically, the assessment is based on a single scan across the symbol, which might be through an exceptionally good, or bad, section of the symbol, and cannot be guaranteed to be truly representative of its condition. Another reason is that measurements of bar width gain or loss are less meaningful in the case of certain symbologies, like EAN/UPC and GS1-128, where decoding relies primarily on edge-to-similar edge distances, which are relatively

immune to even substantial amounts of consistent gain or loss across the symbol. These are measured from the leading edge of one bar to the leading edge of the next (or from one trailing edge to the next), which will tend to move in the same direction if there is bar width gain or loss (see Figure 4-1 below). A fourth, and more subtle, factor is that the method is not standardised, either as to where the "dark" and "light" reflectance (or density) measurements are made for the calculation of PCS, or as to how the exact position of an element edge is defined, so that some models of verifier could assess a given symbol as "In spec." whereas others rejected it – a source of potential and indeed actual commercial disagreements between suppliers and customers.

Newer models of bar code verifiers do still include traditional methods with average bar width deviation, single bar deviations and deviations for edge to edge distances. Using this method, the print process control provides powerful tool for a linear metric print process control. By definition the method according ISO/IEC 15416 is looking from the point of view of a scanner and does therefore not provide the detailed metric analysis of this extended traditional method.

Figure 4-1 : Edge to similar edge measurements: nominal bars (top); with bar width gain (bottom); (measurements A and B are identical to A' and B' respectively)

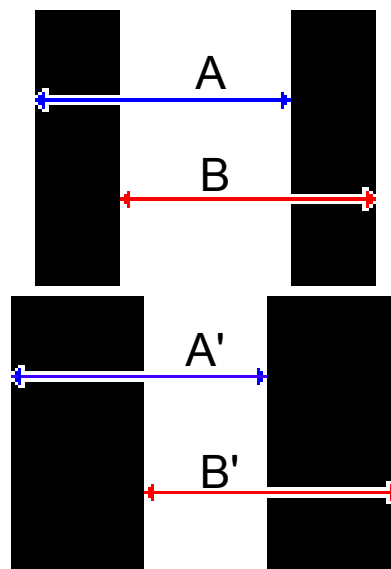

4.3. ISO verification

During the 1980s two factors led to attempts to improve on the traditional technique. One was the disparity between traditional verification results and observed scanning performance and the second being the increasing number of product rejections by customers based on differing verification. This led to a wide-ranging programme of testing of symbols of all kinds, on all types of scanning system, by a group of experts from bar code and user industries, to determine the factors which most directly affected reading performance. The conclusion of this analysis was the concept of using the "scan reflectance profile" as basis for verification. This methodology was originally known as "ANSI verification", because it was first described in the American National Standard ANSI X3.182, published in 1990 under the title "Bar code print quality guidelines". Not long ago, the method was also defined in a European standard (EN 1635) published in 1995 and an International Standard (ISO/IEC 15416) that was published in 2000. This ISO document is the definitive international specification of the "ISO verification method". The method, as described in the ISO standard, is technically fully compatible with the ANSI and CEN method.

The ISO standard is a totally generic print quality standard for linear symbologies. It quotes generalised formula for the calculation of Decodability for two-width symbologies (such as ITF-14) and for edge-to-similar edge decodable symbologies (such as GS1-128 or EAN/UPC) respectively but, instead of giving the specific additional calculations for defined symbologies (such as the special treatment of the 1, 2, 7 and 8 characters and the auxiliary guard patterns in EAN/UPC), it leaves these to be quoted by the International Standard or other formal specification for the symbology in question. Consequently, ISO/IEC 15420, the international symbology standard for EAN/UPC, and ISO/IEC 15417 (for Code 128) has additional text dealing with this.

In simple terms, an "ISO verifier" looks at the symbol in exactly the same way in which a scanner sees it. Although a verifier demands defined environmental conditions (e.g. constant angle, distance and aperture) to get reproducible results, it reports its assessment of the symbol quality, not as a single "Pass/Fail" decision, but as one of a range of four passing grades (from 4 to 1, in order of decreasing quality) or one failing grade (0). This enables an application to set the most appropriate minimum grade for acceptability. It may be noted that the ANSI standard used the alphabetic scale A to D for the "passing" grades and F for "failing" symbols, but the grade thresholds are identical.

The relationship between symbol grades measured in this way, and the way the symbols behaved when they were scanned, was so close that users rapidly came to accept the scan reflectance profile assessment method for verifying symbols received from their trading partners. They knew that, as long as a symbol achieved grade 1.5 (for example) or better, it would give them acceptable scanning performance.

The ISO method does not directly cover print process control or symbol size. However, GS1 standards specify permissible size by application area and it therefore necessary to check the symbol size / magnification.

4.4. Equipment conformance standards

These are aimed at giving users additional reassurance about the consistency of measurement of their instruments and their trading partners' or suppliers', and are important supporting standards for the basic verification one.

ISO/IEC 15426-1, entitled "Bar code verifier conformance testing – Part 1: Linear symbols", published in 2000 defines the basic requirement for a verifier as that of reporting the same results (within close but reasonable tolerances)

Comment: Tolerance for Symbol contrast is +/- 8% both for overall symbol grade and for individual parameter measurements, when verifying a set of test symbols of known grades specified in the standards. The test symbols have been produced to great accuracy with various deviations from ideal for individual parameters (Defects, Decodability, Symbol Contrast etc.) and have been measured to very high precision to show the values that should be given by the verifier. A subset of these symbols is available as the Calibrated Conformance Standard Test Card (see Figure 7-1). The standards also define the functions the verifier must perform and a number of optional ones.

Verifier manufacturers whose equipment adheres to these standards are able to ensure that many of the arguments between suppliers and customers can be avoided, simply because there should be a good deal less variation in results. Variations will never be totally eliminated because the tolerances available on the measurements may just tip a symbol over a grade threshold, but the reasons should be clear when the details are examined.

4.5. History of adoption in the GS1 General Specifications

Until the mid-1990s, no specification for verification was given in the *GS1 General Specifications*. Instead it outlined that provided the appropriate procedures (i.e. the carrying out of printability tests and the incorporation of the results into the bar code master specification) had been followed, and sample symbols had been test scanned by the receiver, there was unlikely to be a problem; if a verifier was used it was a useful tool but should not be relied on conclusively. The first step toward verification was taken in 1994 by

adapting the ANSI methodology specifically to the needs of the EAN/UPC symbology – to which it had previously not been applicable – and the result was then published in 1995 as U.S. standard ANSI/UCC-5. The method was explicitly offered as an optional and independent alternative to the procedurally based approach for producing symbols using a film master.

Today, the *GS1 General Specifications* specifically refer users to the ISO/IEC 15416 as bar code print quality standard and specify the minimum quality requirements by area of application (e.g., minimum and maximum size).

5. What verification does – and its limitations

The job of verification is to check how closely a bar code adheres to its specification, and to highlight the ways in which and the extent to which it deviates from the ideal. Receivers of bar coded goods can therefore estimate how successfully they are likely to perform in the scanning environment in which their application operates, and the producers of the symbol can check how acceptable it is likely to be to their customers and adjust their production conditions, to the extent that they can be controlled at an economical cost, to get as close as possible to the perfect symbol.

The use of a verifier will confirm adherence to specifications in many respects, particularly those related to the symbol's scanning performance, but it cannot provide total assurance that every aspect of every symbol is as required. In general terms, a verifier checks the features of a symbol that ensure that it can be read, but cannot cover its general formatting. Here are a few examples:

- Because traditional verification measurement is typically made in a single scan across the symbol, it is uncertain whether this "snapshot" is truly representative of the symbol's characteristics through the height of the bars. Some verifier manufacturers adopted ISO average measurement also to the traditional parameters.
- Verifiers do not check every aspect of the symbol quality (e.g., bar height, correct usage of the numbering system, etc). Verification services therefore need to manually assess them (e.g., whether excessive truncation has been performed, the GS1 Company Prefix used is valid, etc.)
- Without additional software linking the decoded data to a database, it cannot be confirmed that the data content of a symbol is what it should be. Some manufacturers of verifiers offer as option an included database function.
- The device cannot confirm that the symbol dimensions are what are intended – many of the simpler verifiers cannot measure in dimensional terms though they can be remarkably accurate in measuring the relationships of element widths to each other. This restriction is valid for low end wand verifier (or similar models). More sophisticated verifiers are able to measure absolute symbol dimensions with a very high accuracy. This dimensional verification is usually offered by verifiers including a detailed traditional evaluation. If the symbol generation software does not automatically format the human-readable interpretation from the same data entry as the bar coded data, then it is necessary to check that the two correspond, but a verifier cannot do so.
- Because only a sample of the symbols produced is actually verified, the quality of all the symbols in a production batch cannot be guaranteed beyond the statistical confidence limits associated with the sampling rate used.
- Even a perfect symbol at the time of production can be damaged or otherwise affected in its passage through the supply chain (scratched, frozen, made wet, etc.).

The use of a verifier has therefore to be supplemented with visual inspection and other appropriate checks, such as confirming the GS1 Company Prefix used via <http://www.gepir.org>, in order to perform a total verification process.

6. When to verify

Verification of a symbol may be carried out at a number of stages and the purpose for which it is performed may well vary at each time. As already stated, it is not necessary to verify every single symbol. As a general rule, a sampling basis should be decided upon in the company's ISO 9000 or other quality assurance procedures. The sampling frequency should be increased if symbols are near the borderline for acceptability, or there is reason to suspect problems; it may be decreased if they are consistently well within the acceptable range. See bar code generating process flowchart at [ANNEX C, The process of symbol generation](#).

6.1. In symbol production

This will serve the goals of assessing the acceptability of the symbol to a customer and of improving the quality of symbols through controlling the production process.

6.1.1. At the design stage

Here, there is of course no symbol to verify, but a verifier may be used as a reflectance measuring device (in "reflectometer" mode) on sample patches of the colours to be used for the actual print job, to estimate the symbol contrast achievable. Because of the "modulation" effect (a concept which is explained later), it is recommended that the bar colour should be measured on a narrow strip (about equivalent to the narrow bar width of the symbol) placed on the background colour, and the background colour should also be measured on a narrow strip adjacent to the bar colour. ISO 15416 shows a suitable mask which will assist this measurement.

6.1.2. Film master/electronic origination/volume printing

For the EAN/UPC symbology, the biggest usage of verification has always been in conjunction with printing and production of packaging and labels by means of the conventional or "wet ink" printing processes, such as offset lithography, flexography, rotogravure etc. These used a film master as the initial artwork of the symbol, although this high-precision article is increasingly being replaced by some form of electronic origination of the symbol (CTP – Computer to plate process).

The first point at which one might use verification is the printability test stage prior to actual production of "real-life" symbols, where a printing run of a test symbol is carried out under normal conditions and measured in order to characterise the printing process for a particular press and printing substrate. It is necessary to assess how much bar width growth (or occasionally loss) has occurred, and over what range of variation, to decide how much bar width adjustment (BWR – bar width reduction, where there is bar gain, or BWI – bar width increase, in the less usual case of print loss) and the minimum magnification factor required. These details are required in order to specify the film master correctly, or as input parameters for the bar code origination software.

One might then verify the film master on receipt, to confirm that the correct bar width adjustment has been applied and that it is otherwise as specified. Note that a special type of verifier using traditional measurement and capable of more precise measurement is necessary at this point, since film master requirements are specified in terms of element widths and are subject to tolerances of only ± 5 microns for EAN/UPC symbology. In addition, the verifier needs to be capable of measuring the intensity of light transmitted through, rather than that reflected by, the film material; also, film masters may be either photographic positives or negatives, and in the latter case the light and dark characteristics of the background and bars are reversed. In the absence of such a verifier, reliance may be placed on the verification report normally provided by the film master supplier with the master. ISO/IEC 15421 defines the requirements to film masters. In processes without film masters (which are increasingly common) it makes sense to define that the data in the design be

created in way that a film master manufactured by using this data would be in line with ISO/IEC 15421.

If a proof of the print job is produced, the bar code should be verified as part of the approval process. Note, however, that since proofing presses are not the same as production printing presses, there will be a difference in the quality of the proof and the production job. Some proof processes, for example using ink jet techniques, are mostly unsuitable for verification because variations are too big.

While the presses are being made ready, a check of bar widths on the first few sheets printed can help to ensure that the press is correctly set to produce near-ideal bar widths. Once the presses have started to roll, periodic sampling should be carried out at intervals based on experience or dictated by the company's Quality Control procedures.

Finally, after completion of the print job, a further sampling of the finished job will be performed – this time using the scan reflectance profile analysis as the basis for decision-making – to ensure that the job has achieved at least the minimum quality grade specified by the customer or the applicable part of the *GS1 General Specifications*. Some verifier models provide in one step the scan reflectance profile analysis together with a detailed bar width, bar gain and edge to edge measurement

The packaging supplier's customer may well carry out his own Quality Control checks on incoming packaging materials.

6.1.3. On-demand printing

In this area, typically using thermal, thermal transfer, ink-jet, laser printing or some other techniques for pressure-sensitive label production, the opportunities for process control are more limited. In some cases, the print head temperature, burn time, print speed or pressure may be capable of being regulated to influence bar widths; software adjustments are usually called for here, and occasionally mechanical adjustment of the printer. Or the substrate may need to be changed. But the main job of verification is to check that the quality grade meets minimum requirements. One thing that it will quickly reveal is if an element in the print head has failed (note, a good technique is to print a horizontal bar on top of the symbol making print head failure noticeable to the naked eye).

If the defective element is in the middle of a space, there will be no problem, but there is a good chance that the defective element may fall on a bar module in the next label design to be printed - as in the example in [Figure 6-1](#) below, where it has had the effect of reducing the width of a three-module bar (compare it with the similar bar in the symbol character to the left).

Figure 6-1 : Line above symbol to detect print-head element failure (indicated by arrow)

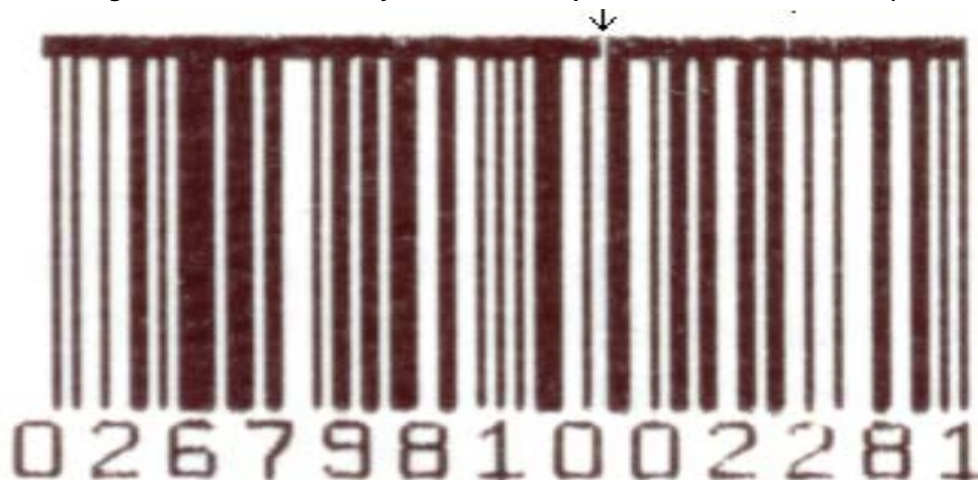

Verifiers can help detect print head failure as one single bar deviation appears much bigger than other bar deviations. At the first level label and ribbon will be selected by getting the most accurate metric results and the lowest defects values (assuming that the other ISO

parameters are within specification). Then the regular verification will help the printer to adjust them for low average and low extreme bar deviation together with low defect values.

6.2. Post manufacture (finished goods despatch/receipt)

The product manufacturer will be primarily concerned with the acceptability of the symbols to customers. Verification to the symbols, both on receipt of any pre-printed packaging materials and on completion of the packaging process, to ensure that the minimum grades set out in the *GS1 General Specifications* have been met. It may be that packaging operations, such as over-wrapping, filling the bottle, or plastic over-wrap, will have introduced some negative factor which reduces the symbol quality. For this reason verification should be carried out on the bar code "in its final configuration".

Intermediate parties in the supply chain, such as wholesalers, will only need to verify symbols, particularly on traded units and transport units, if they are going to scan the products, for example on their automated handling systems or, in the case of a cash-and-carry wholesaler, at the checkout.

Finally, the retail organisation will also verify sample bar codes on items delivered to its distribution centres and stores, as part of its normal goods inward Quality Control procedures. Many retailers also include verification of the bar code as a part of their buying procedure. They will not list a product unless it carries a bar code and that symbol meets the required quality standard. Once in the store, a product which starts to show an unacceptable level of scanning problems at the checkout will also be subjected to a more intense level of verification in order to diagnose the possible causes of the scanning problems.

7. How to use a verifier

The precise operation of any verifier should be in accordance with the manufacturer's instruction manual. Nevertheless, a few simple common principles can be followed to ensure maximum consistency and repeatability of results.

Ensure that the various parts of the instrument – optical head, processor unit, printer, mains adapter – are correctly connected and that the device is configured to verify according to the correct symbology and/or application specification, with a light source of the correct wavelength and a measuring aperture of the correct diameter. It may be possible to select different operating and output options, e.g. enable/disable symbologies and their optional features, single scan or multiple scan averaging, output of overall and individual parameters, output of scan reflectance profiles etc. These should be selected according to need.

Always calibrate the instrument in accordance with the instructions and using the calibration materials supplied – ensuring that the latter are protected from dirt and damage while not in use. Some instruments require manual adjustment of response to the reference reflectance materials; others calibrate themselves automatically, prompting the user as required, usually as part of the start-up routine.

The symbol should be verified in its final configuration wherever possible (i.e. including over-laminate, package material and contents, etc.) but if this is not feasible, the following procedure is recommended to allow for the effects of "show through". Place the symbol to be verified on a flat surface. If the substrate is not opaque, perform the verification procedure with the symbol on a dark surface and then repeat it on a light surface, and take the poorer set of results, unless it is known what type of material is likely to back the symbol in practice, in which case attempt to match it.

If manual scanning is needed, pass the optical head over the symbol from left to right or vice-versa in as smooth a manner and at as constant a speed as possible, neither too slowly nor too fast, and if multiple scans are intended, space these evenly through the height of the symbol without running out of the top or bottom boundaries of the symbol. Sometimes a ruler can be used as a guide, depending on how the instrument is constructed.

7.1. Importance of calibration

The scan reflectance profile is a plot of reflectance variations across the symbol, from which all the other calculations are made. The verifier must, therefore, measure reflectance accurately. It is extremely important to ensure that the instrument is properly calibrated – in other words that its reflectance measurements are matched to the known reflectance of the calibration plaque or test symbol provided by the equipment supplier. Not only does this ensure correct grading, but also consistency and repeatable measurement. Inadequate calibration will either prevent operation of the instrument, or lead to strange results and varying quality grades.

7.1.1. Calibration Frequency

Verifier manufacturers always provide calibration instructions. It is absolutely vital that these calibration instructions are followed. It is not sufficient only to calibrate the verifier when it is first installed and activated. If manual calibration is performed, it should be done under the same environmental conditions used for the grading of bar codes under test. For maximum consistency, regular re-calibration, at least as frequently as recommended by the manufacturer, is recommended. Typically re-calibration should occur at regular intervals in line with the manufacturer's recommendation, or after a substantial period of inactivity, or whenever there is an environmental change such as lighting conditions. The verifier must always be recalibrated if the scan head, the measuring aperture, or scan width is changed.

7.1.2. Calibration materials

Most manufacturers provide calibration materials that have accurately specified reflectance characteristics. Care of these materials, which may be either a test symbol or a ceramic or enamel reflectance tablet, is extremely important. Packaging and storage of the materials must be in accordance with the manufacturer's instructions. Prompt return of the materials, after use, to their safe storage area is key to their continued reliability.

7.1.3. Calibrated Conformance Standard Test Card

GS1 make available calibrated test cards, produced and measured to a high degree of accuracy, enabling users to check that the readings obtained on their equipment are consistent and accurate. They contain both 'perfect' and engineered 'less-than-perfect' symbols (see [ANNEX B](#), [Use of Calibrated Conformance Standard Test Card](#) for full details of the test cards).

Figure 7-1 : Calibrated Conformance Standard Test Card

CALIBRATED CONFORMANCE STANDARD
TEST CARD
FOR EAN/UPC SYMBOL VERIFIERS
USING 6 MIL APERTURES

<p>EAN-13 MASTER GRADE</p> <p style="font-size: 8px;">5 0 1 2 3 4 5 6 7 8 9 0 0</p> <p>DECODABILITY: <u> Z </u></p> <p>CONTRAST: <u> Z </u></p> <p>MODULATION: <u> Z </u></p>	<p>UPC-A MASTER GRADE</p> <p style="font-size: 8px;">0 1 2 3 4 5 6 7 8 9 0</p> <p>DECODABILITY: <u> Z </u></p> <p>CONTRAST: <u> Z </u></p> <p>MODULATION: <u> Z </u></p>
<p>DEFECTS (VOID)</p> <p><u> Z </u></p>	<p>DECODABILITY (BARI)</p> <p><u> Z </u></p>

CALIBRATION #: _____

WAVE LENGTH: 670 nm

EFF. APER.: 0.006 in.

CONTRAST

 Z

BarCodes and eCom™

• PER ANSI K3182
 • PER ISO/IEC 15418 STANDARDS

DATE ISSUED: _____
 THE STANDARD IS CERTIFIED FOR 2 YEARS FROM IN SERVICE DATE
 WHEN USED IN ACCORDANCE WITH USE OF CALIBRATED
 CONFORMANCE STANDARDS DOCUMENTATION
 © 2008 GS1 US. ALL RIGHTS RESERVED

PART NO. CCSV-1 REV Q-2

7.2. Selection of aperture/light source

It is equally important to match the light source to that to be used in the application, and the measuring aperture to the X dimension range of the symbols to be verified.

The wrong light source – specifically, one whose peak wavelength deviates from that specified – will lead to inaccurate contrast measurements, particularly where the symbol bars and/or background are coloured rather than black or white. For GS1 verification 670 nanometres in the visible red part of the spectrum is preferred because this wavelength is close to the wavelengths most commonly used by laser diode scanners and the LED in CCD scanners.

The measuring apertures to be used are defined in the *GS1 General Specifications*.

7.3. Scanning the symbol

According to ISO/IEC 15416 standard (also ANSI X3.182 and EN 1635, ANSI/UCC5 for EAN/UPC Codes) a symbol should be measured by 10 (ten) scans at different heights (Figure 7-2).

Figure 7-2 : Ten scans of symbol verification

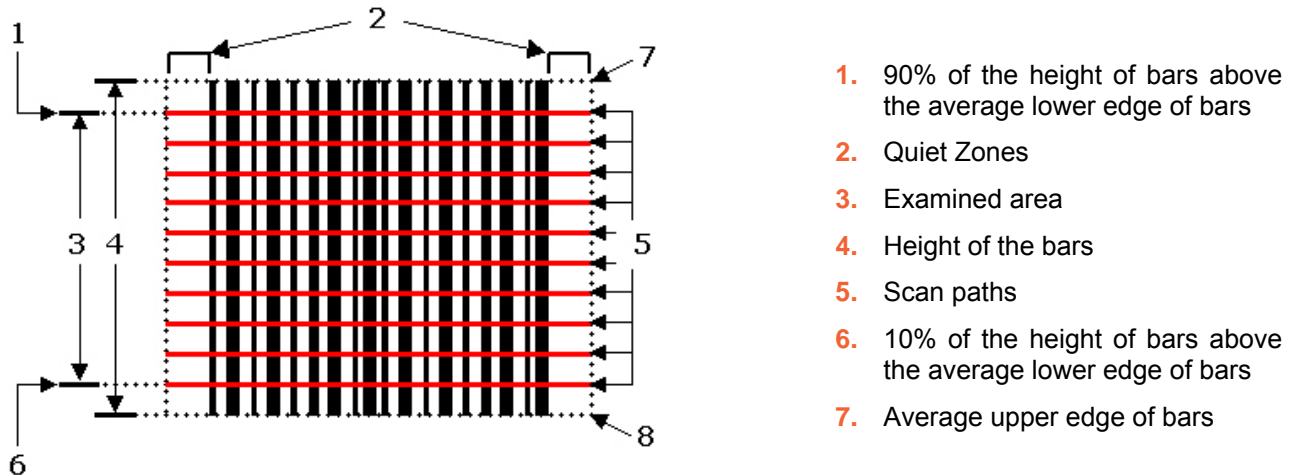

7.3.1. Hand-scanned verifiers

The scan heads containing the optical components can be of different types from device to device but the operating principle is the same. The scan head must be moved manually across the symbol to generate the scanning action.

With a wand-based verifier, the tip of the wand should be placed on the area somewhat to the left of the symbol and the wand itself inclined at an angle of 15° or so from the vertical, or at the angle specified by the supplier. Many of these verifiers have a plastic guide fixed to the wand to ensure that the angle of inclination is correct and consistent from one scan to another. Ensure that the symbol is lying on a flat surface - bumps or irregularities will prevent a smooth scan and lead to unpredictable and inaccurate results. The wand should then be passed smoothly and at a reasonable speed across the symbol, up to ten times, traversing a different part of the symbol each time. Learning what is the best scanning speed, is a matter of practice; if scanned too slowly or too fast, the instrument will simply fail to decode the symbol, or it may prompt the user to adjust the scanning speed.

The same technique should be used with a verifier with a mouse as its optical head.

Care must be taken to avoid the following problems:

- The scan path exits the top or bottom of the symbol (Figure 7-3), resulting in mis-scans, or short reads of some symbols such as ITF-14.

Figure 7-3 : "From top to bottom" scan



- The scan path runs too close to the top or bottom edge of the symbol (Figure 7-4), giving the possible result of poor modulation values due to interference from the light area above or below the symbol.

Figure 7-4 : “Close to the top” scan



- Irregular or curved scanning motion ([Figure 7-5](#))—results in acceleration or deceleration during the scan and leads to varying Decodability values.

Figure 7-5 : “Curved motion” scan



- The scan path starts or finishes too close to the symbol ([Figure 7-6](#)). This frequently leads to failure to decode or Quiet Zone failure. It is almost always accompanied by excessive acceleration or deceleration through the first or last symbol characters resulting in a low Decodability grading.

Figure 7-6 : “Too close start or finish” scan



- Scratching of symbol surface due to dust or other contamination of scan head.

Good scanning practices must involve starting the scan at a point where there is a good likelihood that a constant scanning velocity is achieved as the beam crosses the Quiet Zone and then maintaining a constant velocity as the scanning beam crosses the entire bar code. The scanning instrument must be held (per manufacturer’s instructions) at the correct angle while scanning across the bar code. Improper angle orientations are likely to result in incorrect scan grades.

Problem Minimisation

- Use a straight edge or similar guide to guide the motion of the scan head.
- Keep the scan head and applicable optics clean and free of dust.
- Whenever possible verify in the final form, but when impossible, verify flat.
- Provide adequate operator training.
- Employ smooth scanning action.
- Calibrate instrument as recommended for aperture and ambient light.
- Use the Calibrated Conformance Test Card ([ANNEX B](#)) to train operators.
- Choose an appropriate background when verifying symbols printed on a transparent or semi-transparent.

7.3.2. Automatically scanned verifiers

This category includes all verifiers where the scanning action is automatically performed and does not rely on the operator to physically move the scan head across the symbol. The category includes CCD (linear array or camera-based) and laser-based verifiers employing motorized optical head transports or a controlled rastering operation to sweep the scan beams down the symbol. The most frequent problem with this style of verifier has to do with symbol positioning. The scanning beam starts outside the Quiet Zone of the symbol and crosses the symbol completely. Some “automatic” verifiers may perform automatic scanning of the horizontal beam across the bar code, but require manual positioning of the scanning head from top to bottom (ten scan paths) of the symbol for individual scans to obtain symbol grades. Some Automatic Scanning Verifiers can determine module width. This feature is useful for confirming adherence to the module size ranges specified for the various symbols and applications in the *GS1 General Specifications*.

Problem Minimisation:

- Position the symbol and the scan path to ensure that the entire inspection area is covered.
- Keep the scan head and applicable optics clean and free of dust.
- Whenever possible, verify in the final form, but when impossible, verify flat.
- Provide adequate operator training.
- Calibrate instrument for aperture and ambient light. Be sure to use the proper aperture for the symbol.
- Use the Calibrated Conformance Test Cards ([ANNEX B](#)) to train operators.
- Choose an appropriate background when verifying symbols printed on a transparent or semi-transparent substrate.

7.4. What additional steps need to be taken (e.g. visual inspection)?

Verifiers do not assess every characteristic of a symbol for conformity with all the specifications appropriate to the application. So a visual check must be carried out as part of the verification process. This will help ensure that the encoded data is what is expected (although some verifiers do have a database look-up facility which can confirm the validity of the data). Formatting of the data shall be checked. If a verifier does not have specific programming for GS1-128 symbols, and these are being verified using the standard Code 128 rules, the basic quality grade of the symbol will be identical but it is necessary to check from the display of decoded data that the use of FNC1 is correct, both in the first position after the Start character and when separating variable length data fields. Also check that parentheses surrounding Application Identifiers in the human-readable interpretation do not also feature in the encoded data. Some verifiers are able to check that the data field associated with each Application Identifier is in the correct format.

Truncation of the symbol should be strictly controlled to reduce loss of the omnidirectional scanning ability of EAN/UPC symbols. This cannot always be checked by means of a verifier, so again visual inspection, and often the use of a ruler to check bar height, is appropriate.

Wherever possible the symbol should be checked visually on the final package (even if it cannot be verified in this final format) to ensure that it is correctly positioned in accordance with guidelines, and particularly that folds, seams or flaps do not encroach on the Quiet Zones or the symbol itself.

8. Scan reflectance profile analysis

8.1. What is a scan reflectance profile?

It is an analogue plot of the light reflected from the symbol as a scanning spot or sampling aperture moves across it. The x-axis of the plot shows linear distance across the symbol, while the y-axis shows the reflectance values. Light areas show high reflectance values; dark areas show low values. The profile therefore consists of a series of peaks and valleys, the widths of which are proportional to those of the bars and spaces. There is not an instantaneous transition from the low to high reflectance values or vice versa, but the transition slopes steeply, since when the aperture is crossing a bar edge, its area covers both light and dark areas in proportions which change progressively as the spot moves over the edge.

Figure 8-1 : Scan reflectance profile of a UPC-A Barcode

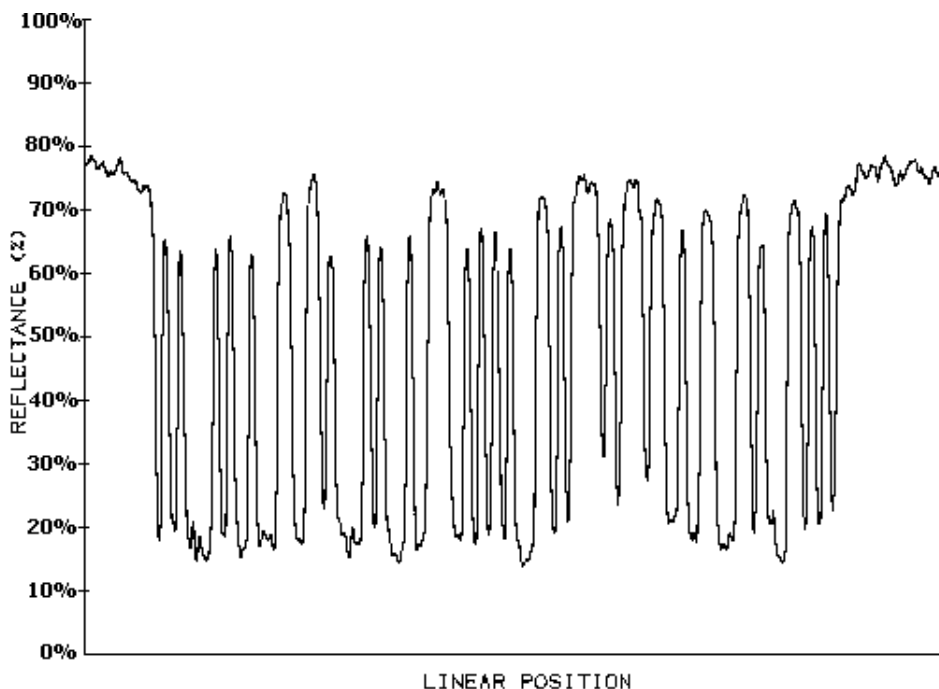

The scan reflectance profile is a picture of the raw material which a scanner uses to derive a digital reconstruction of the bar and space pattern forming the symbol, which the decoder then interprets back into its original data values.

For this reason, verification based on analysis of a scan reflectance profile is able to show very close correlation with scanning performance.

8.2. Pre-conditions for obtaining the profile (lighting, aperture)

If the verifier is to match the performance of a scanner closely, and to predict how it will perceive the symbol, the conditions must be as similar as possible. In order to ensure reproducibility and consistency, they must also be standardised.

The ISO standards set out a reference **optical arrangement** (Figure 8-2), consisting of a source of flood incident light at 45° to the surface and a collector (through an aperture) of the diffusely reflected component of this light, at right angles to the surface. The vertical plane in which the light source is located is parallel with the height of the bars. This set-up is intended to minimise the effect of specular (mirror-like) reflection from glossy surfaces. Not every

verifier matches this set-up. Some simply reverse the arrangement by having a point light source and narrow beam (e.g. laser light) and a larger collecting area, but the results are likely to be close to those of the standard set-up. Others - for example, verifiers using a wand – do not match the 45°/90° angles, but provided that the user avoids holding the wand at an angle where specular reflection might be a problem, they will still give adequately accurate results. Many of the latter have a special guide affixed to the wand to help the user to keep to the optimum angle.

Figure 8-2 : Reference optical arrangement (1 Light sensor, 2 Aperture, 3 Optical obstruction, 4 Verified sample, 5 Light source)

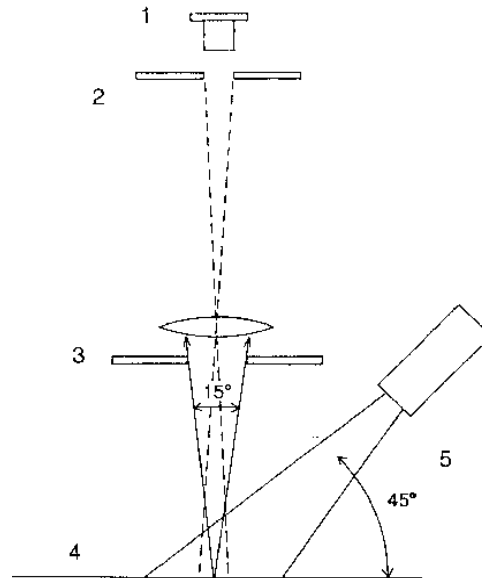

The **light source** and/or collector are chosen so that the peak wavelength of the measured light is the same as will be used in the scanning application for which the symbols are intended. For most bar code scanning today, this light is in the visible red area of the spectrum; most scanners use either visible laser diode or light-emitting diodes (LEDs) with a peak wavelength around 660 – 670 nanometres; these have virtually replaced the previously commonly used Helium-Neon laser tube which peaked at 633 nanometres. The light wavelength is extremely important since the spectral responses of the pigments in printing inks, and of the substrates on which symbols are printed, mean that they absorb and reflect different amounts of light when the light wavelength changes, even by relatively small amounts. This effect is most apparent with coloured inks and substrates. With black printing on white paper the differences are smaller, except in the case of some thermal label stock where the light absorbency of the dark bars starts to decrease to negligible proportions somewhere around 680 - 700 nanometres, and so their apparent reflectance increases. So variation in the peak wavelength of the verification instrument from that of the scanning system becomes a major source of discrepancies.

Unwanted light falling on the symbol under test is a frequent cause of otherwise apparently inexplicable variances in verification results. If the verifier design is such that the optical head is not adequately shielded from light from external sources, ambient lighting conditions should be controlled as far as practicable. ISO/IEC 15426-1 calls for manufacturers to specify the levels of ambient lighting under which their instrument can still operate correctly. Examples of potentially interfering lighting include direct sunlight, indirect sunlight if it causes high light levels at the verification location, high-intensity lighting such as high-pressure sodium or mercury vapour lamps (which may have strong red components in their spectral distribution), and fluorescent lighting (the flicker can be perceived by the verifier as spurious dark and light patterns). High ambient light intensities will cause apparent reflectance to increase, or reduce apparent contrast, or may even completely drown the light reflected from the symbol. Many verifiers include a narrow-pass (notch) filter in the optical train, allowing

only light close to the 670 nm wavelength to get through to the light-sensitive element; this may reduce but will not always completely block unwanted light from reaching the light-sensitive component.

Similarly, the diameter of the **measuring aperture** (or size of the scanning spot) relative to the width of the bars is also very important.

If the aperture is **too small** ([Figure 8-3](#)), small imperfections and local variations in reflectance will have a much greater impact on the scan reflectance profile than they should. The Defect grade will be worse, and the grade for Modulation may be improved (because minimum edge contrast may be over reported).

Figure 8-3 : Example of too small aperture size



If the aperture is **too large** ([Figure 8-4](#)), it will never be entirely contained within the width of a narrow element, thus reducing the apparent contrast of that element with its neighbours. The edge contrast minimum, and therefore modulation, will be reduced. It will also not detect defects as accurately.

Figure 8-4 : Example of too big aperture size



Either way, the measured symbol grade will be lower than it deserves to be. Only the use of the correct aperture for the X dimension of the symbol under test will ensure that the grade established from measurement of a symbol is the correct grade according to the method specified in ISO/IEC 15416.

The aperture should be around 80% of the smallest X dimension to be encountered in the application. In the case of EAN/UPC symbology, an aperture of 0.15 mm (6 mils), is required no matter what the X dimension. This was determined by verifying a range of symbols with several different apertures and comparing the results with performance on a range of POS scanning systems. The 0.15 mm (6 mils) aperture gave the best correlation with scanning results.

The table below summarises the specified aperture sizes for verification of the various symbols used (see the *GS1 General Specifications*). These were defined for the other symbologies following a similar principle to that adopted for EAN/UPC symbols.

Table 8-1 - Measurement apertures for symbols

Symbology	Aperture reference	Nominal diameter	
		Mils (0.001")	Millimetres(mm)
EAN/UPC	06	6	0.150
GS1 DataBar	06	6	0.150
GS1-128	10	10 ¹	0.250
ITF-14, $X < 0.635$ mm (0.025 inch)	10	10	0.250
ITF-14, $X \geq 0.635$ mm (0.025 inch)	20	20	0.500

The light wavelength at which measurements are made, and the diameter of the aperture used, are therefore important attributes of the symbol quality grade and must always be reported with it. The format 1.5/06/670 specified for this includes respectively the overall symbol grade (in this case 1.5), the aperture reference number in mils (in this case 6 mils) and the light wavelength (in this case 670 nm).

8.3. Analysis of the profile and symbol grading

The scan reflectance profile is analysed in terms of a series of parameters. A number of these are reflectance-related, such as Maximum and Minimum Reflectance, Symbol Contrast, Defects, Edge Contrast and Modulation, while some bear more relationship to dimensional features (Decode and Decodability).

First, the profile is divided into candidate bar and space regions by setting a Global Threshold midway between the highest light reflectance (R_{max}) and the lowest dark reflectance (R_{min}) measured anywhere in the scan; areas above the Global Threshold are treated as spaces and those below it as bars. For the detailed parameter analysis, each element edge position is determined, not where the profile crosses the Global Threshold, but where it passes through the reflectance value midway between the peak reflectance of the adjoining space and the lowest reflectance of the adjoining bar. In Figure 8-5 below, the peak reflectance of the wide space is 74%; the lowest reflectance of the adjoining bar is 10%, giving an Edge Contrast of 64%, half of which is 32%, so the edge between the two is located at reflectance value $10 + 32 = 42\%$. Similarly, the Edge Contrast between the bar and the space to its right is 52%, so the edge in this case is located at reflectance value $10 + 26 = 32\%$. The Global Threshold is shown by the solid line at reflectance 40%.

¹ The GS1 Common Currency Coupon Code requires an aperture of 6 millimeters.

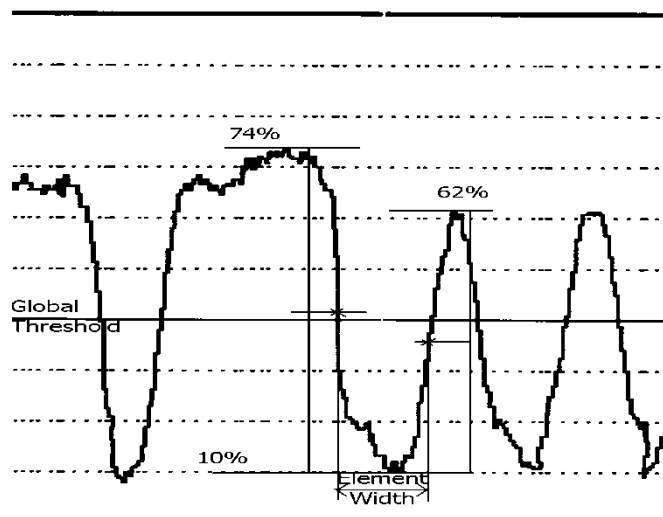
Figure 8-5 : Illustration of edge location in a profile

Each parameter value is graded: some on a pass/fail basis, others on a five-step scale. Annex A shows the values of each parameter corresponding to the thresholds between grades. Each scan reflectance profile is then given a profile grade, which is the lowest of any of the individual grades for the parameters in that profile (on the principle of the weakest link in a chain). Finally, the overall symbol grade is the average of the profile grades. Since the parameter grades are integer values from 0 to 4 (corresponding to the alphabetic steps F, D, C, B and A, as indicated in Figure 8-6 below), the profile grade will also be an integer, but the overall symbol grade will be expressed to one decimal place, in conjunction with the aperture reference number and the peak wavelength, as described earlier.

Figure 8-6 : Equivalence of alphabetic and numeric grades

Figure 8-7 : flowcharts showing the symbol grading process.



8.4. Parameters measured and their significance

The following scan reflectance profile shows an example of the parameters measured.

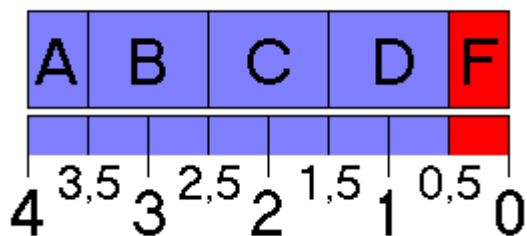
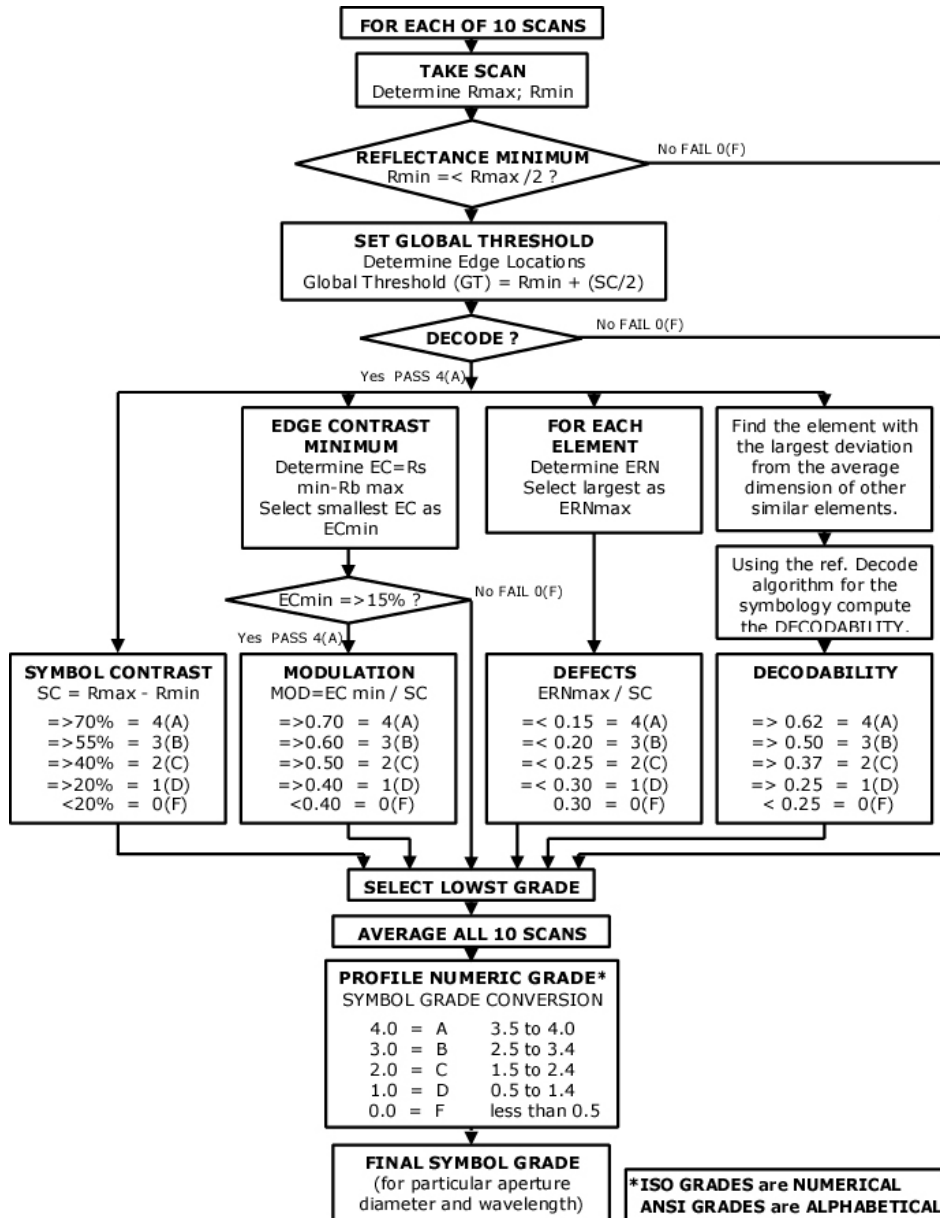
Figure 8-8 : Scan reflectance profile with key measurements indicated

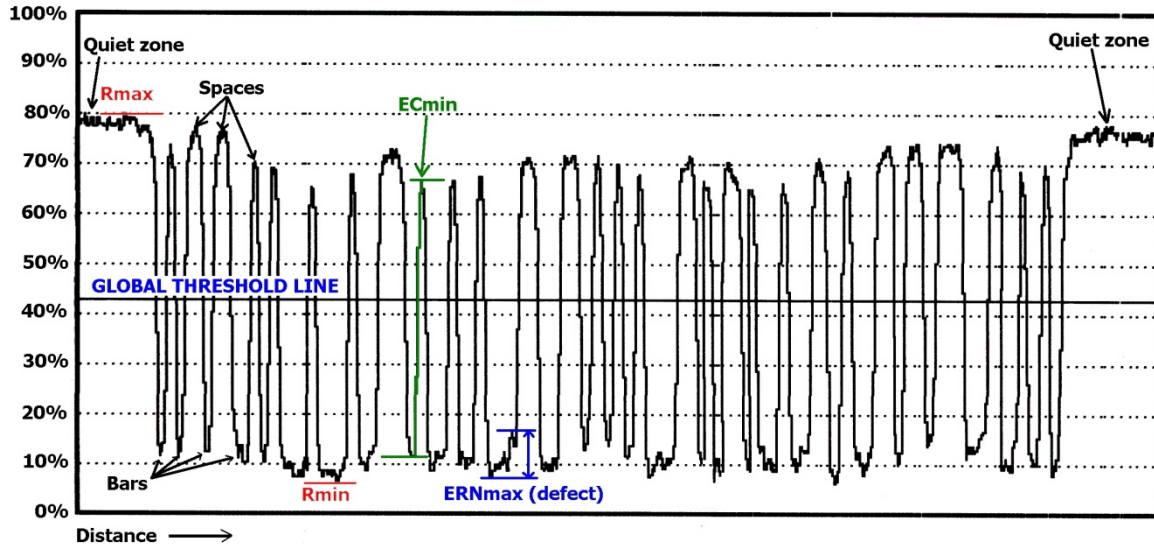

The key values shown in Figure 8-8 above have great significance in the evaluation of the profile. In this case, R_{max} (80%) is found in the left Quiet Zone and R_{min} (6%) is located in bar 7 (counting from the left), enabling the Global Threshold to be set at 43%. The minimum Edge Contrast value is found on the trailing edge of bar 9 ($67\% - 12\% = 55\%$). The most significant defect is located in bar 12, with a depth of 9%. The positions of individual element edges are not shown on the above profile, although some verifiers do show these positions, and highlight the critical parameters in various graphical ways.

8.4.1. Decode

The first step in analysing the profile, after identifying the bar and space regions in the profile and determining the position of each element edge, is to apply the reference decode algorithm - the set of rules/steps for decoding a symbol defined in the symbology specification - to the elements "seen" in the scan reflectance profile. If a valid decode results, the decode parameter passes and is given grade 4, otherwise it fails (grade 0). If the wrong number of elements is seen, the decode clearly fails. Note that in the ANSI standards this last case is graded separately as an "edge determination" failure, although the final effect on the profile grade is the same.

8.4.2. Symbol Contrast (SC)

The Symbol Contrast is the difference between the highest and the lowest reflectance values in the profile. The maximum reflectance (R_{max}) may occur anywhere, in a space or a Quiet Zone. The minimum value (R_{min}) will always be in a bar. The importance of this parameter is that the higher the Symbol Contrast, the more easily distinguishable from each other the bars and spaces will be. SC of 70% or higher is graded 4, while SC below 20% is grade 0.

8.4.3. Minimum reflectance (R_{min})

R_{min} must always be no higher than half of R_{max} . This is because, for a given level of Symbol Contrast, many scanners have greater difficulty distinguishing relatively light bars against a high-reflectance background than they do darker bars against a relatively low reflectance background. This will tend only to affect symbols with grade 2 or 1 Symbol Contrast, where the value of R_{max} is in the upper part of its range. It is a pass/fail parameter: it is assigned grades 4 or 0. The symbol shown in Figure 8-9 below, printed in light brown on a white background (which appears to give good visual contrast) yielded a scan reflectance profile (Figure 8-9) which failed on this criterion. R_{max} was 83%, so that R_{min} should have been 41.5% or less; the actual R_{min} was 43%.

Figure 8-9: Symbol with failing minimum reflectance and associated Scan Reflectance Profile showing failure to meet R_{min} criterion

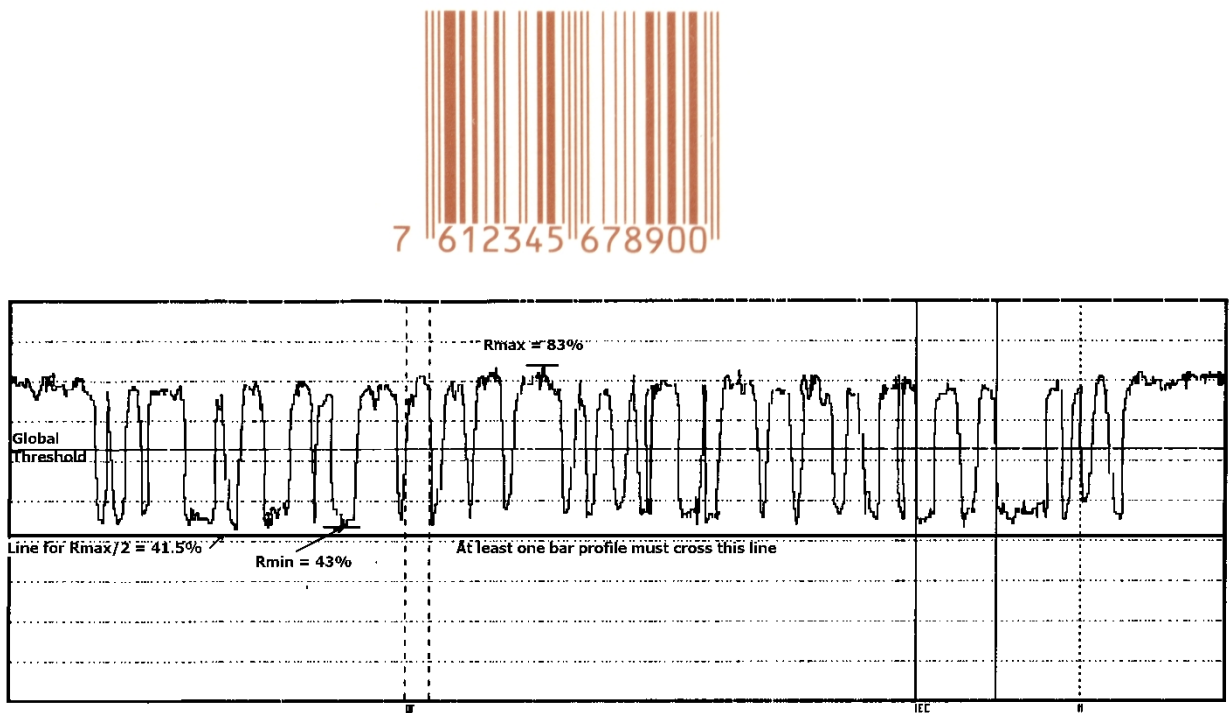

8.4.4. Edge contrast (EC)

This is a measure of local contrast between two adjacent elements. It is defined as the difference of the highest and lowest reflectance values (R_s and R_b respectively) in a pair of adjacent elements (bar + space or space + bar). Quiet zones are considered spaces for this purpose. Every element has its own value of R_s or R_b . The lowest Edge Contrast (EC_{min}) in a profile determines the grade for the parameter; this is also a pass/fail graded parameter (grades 4 or 0 only) where, if EC_{min} is less than 15%, it is graded 0. Variations in ink weight in different parts of a symbol, or fluctuations in the background reflectance (e.g. with corrugated brown kraft substrates) are one cause of Edge Contrast problems, but another is that scanners tend to see narrow elements less distinctly than they do wider ones (a narrow space has lower apparent reflectance than a wide one, and a narrow bar appears similarly lighter than a wide one). Figure 8-10 illustrates a profile where the lowest Edge Contrast is 55% ($67\% - 12\%$).

Figure 8-10 : Scan reflectance profile showing edge with lowest Edge Contrast

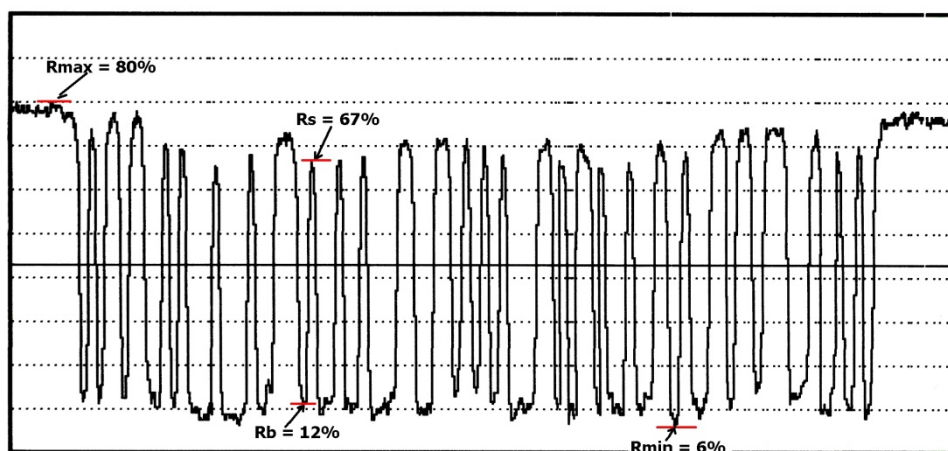

8.4.5. Modulation (MOD)

This parameter is related to the previous one, and is a measure of Edge Contrast as a proportion of Symbol Contrast. Low Modulation values will be caused by the same factors as low Edge Contrast. The difference is that Modulation relates Edge Contrast to Symbol Contrast ($MOD = EC_{min}/SC$). A low Edge Contrast value carries a greater risk of causing poor reading results when Symbol Contrast is high than the same Edge Contrast value has when Symbol Contrast is low. In the profile in Figure 8-5 above, the minimum Edge Contrast value of 55%, when divided by the Symbol Contrast of 74%, gives a MOD value of 0.74, which would be graded 4.

8.4.6. Defects

Spots of ink in the Quiet Zones or spaces, or light areas in the bars, will cause a ripple in the scan reflectance profile at the point where the scan path crosses them. This is referred to in the profile analysis as Element Reflectance Non-uniformity (ERN). In the profile of a space, they show as a valley; in that of a bar, they show as a peak. If this peak or valley approaches the threshold between light and dark, the risk of the element being seen as more than one, and of the scan failing to decode, increases. As already indicated, the use of the correct measuring aperture ensures that the effect of defects is not exaggerated or underrated. The defect parameter measures the relationship of the depth of the highest peak or deepest valley to Symbol Contrast ($Defects = ERN_{max}/SC$), indicative of its relative severity.

Figure 8-11 : Scan reflectance profile of a bar with a Grade 1 defect

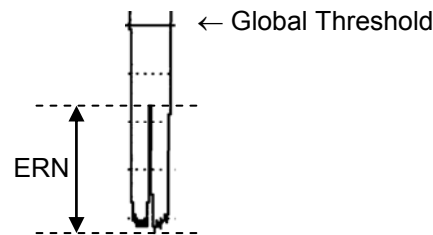

8.4.7. Decodability

Although a fairly easy concept in principle, Decodability is harder to explain in a few words. It measures how close the dimensions within the symbol are to their ideal values, and as such is a measure of its dimensional accuracy. However, it only applies to those measurements needed by the decode algorithm to determine the width of an element, or the combined widths of elements, in order to decode the symbol character. Taking a simple case, if it is a question of determining a particular width, the decode algorithm might say something like "If the measurement is between 2.5 modules and 3.5 modules, treat it as equal to three modules." In other words, 2.5 modules is the threshold value between two modules and three modules, and 3.5 modules is the upper threshold between three and four modules; there is a 0.5 module margin on either side of the nominal measurement of 3.0. Decodability measures how much of this margin is left in the worst (most deviating) measurement: assume the measurement is 2.7 modules, then only 0.2 is left between the actual measurement and the 2.5 threshold, out of the total margin of 0.5, so the Decodability value is $0.2/0.5$, which is 40%. The lower the Decodability, the harder it will be for a decoder to decode the symbol. Some symbologies have particular features which require a more complex Decodability calculation, and the relevant ones are briefly discussed in the sections on EAN/UPC and GS1-128. Generally speaking, Decodability values should not be used for process control purposes, since they only refer to a single measurement; the measurement of average bar width deviation is much more reliable.

8.4.8. Bar width deviation (non-graded)

Bar width deviation is a non-graded parameter, and represents the traditional measurement contribution to the ISO method. It is calculated as the mean difference between measured bar widths and their theoretical ideal values, and may be expressed either as a percentage of the X dimension or in dimensional terms.

9. Interpreting the results

When a symbol is verified the verifier will report on what it has found, either in some form of display or in a printed report. [ANNEX D, GS1 Bar Code Verification Template](#) illustrates a typical report from a commercially available verifier; other manufacturers' products may present the information in a different format but the information reported will generally be similar. The first thing to look at is the overall symbol grade, which is a general statement of the symbol's quality level. If it is close to, or below, the minimum acceptable, the user will need to look at individual parameters to see why the grade is depressed. He will also need to understand what affects the parameters in order to determine the real cause of the grade being low.

10. Potential causes of less-than-perfect grades

10.1. By parameters

10.1.1. Reflectance parameters

Symbol contrast is governed by the reflectance of the substrate and ink. A symbol printed in black ink on a white paper will almost certainly be a grade 4 symbol for Symbol Contrast, as white papers typically have reflectance in excess of 75% and black ink will usually be around 3 - 8% reflectance. Coloured backgrounds or coloured inks will affect the result. Highly glossy materials may also appear to have a lower background reflectance than expected. The worst case may be when printing on a corrugated kraft material which may have a reflectance in a range between 27% and 40%, so even with a very dense, low reflectance ink it can never achieve better than grade 1 for Symbol Contrast (grade 1 includes SC values from 39% to 20%).

The causes of low Symbol Contrast and the solutions are:

Cause	Solution
Background too dark.	Use lighter or less glossy material or change background colour (if printed) to one with higher reflectance.
Transparent printing so the contents are visible through the bar code.	Use more opaque material for package, or print opaque white underlay prior to printing symbol
Bars too light.	Change bar colour for one with lower reflectance, increase ink weight or print head temperature (thermal printing) (N.B. watch for consequential increase in bar widths)

Minimum reflectance, or R_{min} must always be equal to, or less than, half the highest reflectance value, R_{max} . In practice, this means that the reflectance of at least one bar must meet this criterion. Suppose that R_{max} is 70%, then at least one bar must have a reflectance of 35% or less. A symbol failing on this parameter will almost certainly also have a, low Symbol Contrast grade.

The cause of R_{min} being too high is:

- Bars too light. Solutions: Change bar colour for one with lower reflectance, increase ink weight or print head temperature (thermal printing) (N.B. watch for consequential increase in bar widths)

Minimum Edge Contrast (EC_{min}) will always be lower than Symbol Contrast, but will only be a problem in itself if it approaches or drops below 15% (the pass/fail threshold). However, low Edge Contrast values, acceptable under this criterion, may still cause low Modulation grades.

The causes of a low value of EC_{min} , and the possible remedies, are:

Cause	Solution
Local variations in background reflectance, e.g., fragments of darker material in a recycled material.	Use a more consistent substrate or one with higher reflectance
Local variations in inking of the bars	Adjust press settings to ensure even inking
Show through of contents	Use more opaque material for package, or print opaque white underlay prior to printing symbol
Elements adjoining the edge in question excessively narrow relative to the measuring aperture used	Increase X dimension; Ensure correct measuring aperture is used; Ensure correct bar width adjustment applied to film master/original symbol; Print bars marginally narrower than spaces of same modular dimension

Modulation, being calculated as the percentage of Symbol Contrast represented by the minimum Edge Contrast, will be reduced for the same reasons as minimum Edge Contrast is low in the symbol. A scanner will tend to see spaces as narrower than bars, and also to see narrow elements as less distinct than wider ones. Consequently, if there is significant bar width loss, Modulation will be reduced. Measuring with overly large aperture will also reduce Modulation.

The causes of a low value of Modulation, and the possible remedies, are:

Cause	Solution
Local variations in background reflectance, e.g., fragments of darker material in a recycled material.	Use a more consistent substrate or one with higher reflectance
Local variations in inking of the bars	Adjust press settings to ensure even inking
Show through of contents	Use more opaque material for package, or print opaque white underlay prior to printing symbol
Elements adjoining the edge in question excessively narrow relative to the measuring aperture used	Increase X dimension; Ensure correct measuring aperture is used; Apply correct bar width adjustment when originating symbol Print bars marginally narrower than spaces of same modular dimension
Too much bar gain	Apply correct bar width adjustment when originating symbol; adjust press or printer settings.

10.1.2. Other parameters

Decode is graded on a pass/fail basis by applying the reference decode algorithm to the edge positions and element widths determined for the symbol. A failure to decode may be evidence of the symbol being incorrectly encoded, which may include an incorrect check digit. Or it may indicate either that the bars and spaces initially identified by the Global Threshold are too many/too few for a valid symbol or that one or more edge position is ambiguous.

The possible causes of decode failure, and possible remedies are:

Cause	Solution
Symbol incorrectly encoded.	Re-originate symbol; over-label with correctly encoded symbol
Check digit incorrectly calculated.	Correct software error in origination system; re-originate symbol; over-label with correctly calculated symbol
Gross element width errors due to excessive bar gain or loss, or to defects.	Apply correct bar width adjustment when originating symbol; adjust press or printer settings
Too many elements detected due to defects.	Correct cause of defects; adjust press (relief printing processes) to reduce haloing; replace print head (thermal/ink-jet printing)
Too few elements detected (failure to cross Global Threshold).	(as for Edge Contrast)

In the ISO standard, a "Decode" failure because an incorrect number of elements has been perceived to be present, either because the profile of one or more elements has failed to cross the Global Threshold, or because a gross defect has caused one element to be seen as three or more, corresponds to the separately graded "Edge Determination" failure in the ANSI standard which may also be reported by some verifiers following the ANSI methodology.

Figure 10-1 below shows a symbol in which the narrow spaces have been partly filled in, reducing their contrast below the Global Threshold and causing an "edge determination" or decode failure. This could also be interpreted as an extreme example of modulation.

Figure 10-1 : Symbol with "edge determination" problem and associated Scan Reflectance Profile showing narrow space profiles failing to reach Global Threshold, giving Decode failure



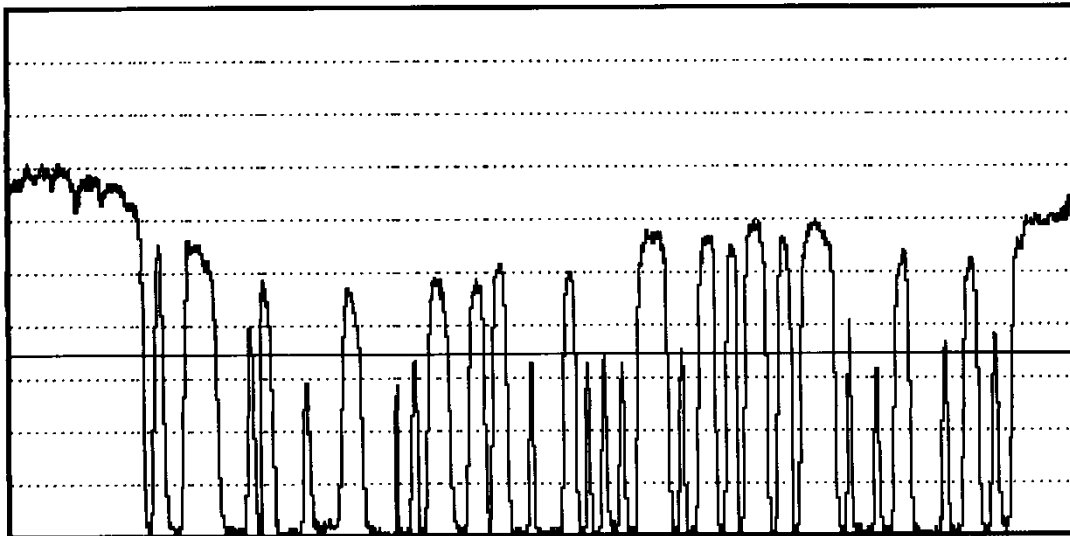

Decodability grades are influenced by bar width growth or loss in most symbologies, and by distortion of the symbol. Distortion can occur with relief printing processes such as flexography, when the printing plate is stretched around the press cylinder with the bars parallel to the cylinder axis (i.e. at right angles to the print direction). A common reason with digitally originated images is that they have been rescaled in graphics software, resulting in uneven addition or removal of pixels to or from the element widths. Print processes which tend to produce irregular bar edges, such as ink jet and rotogravure, will also be likely to give lower Decodability grades.

The causes of a low value of Decodability, and the possible remedies, are:

Cause	Solution
Bar width gain/loss (systematic).	Apply correct bar width adjustment when originating symbol; adjust press or printer settings.
Element width gain/loss (non-systematic).	Correct missing pixels (burnt-out print head elements, blocked ink-jet nozzles); rectify cause of defects.
Distortion of symbol (uneven stretching of flexographic plate; non-linear disproportioning in plate-making process).	Print symbol with height of bars parallel to direction of printing; do not disproportion bar code image in plate-making.
Rescaling of digitally originated images.	Ensure symbol is created in correct size; ensure software matches module widths to integer number of pixels after all adjustments.
Irregular element edges (ink-jet, rotogravure, screen process printing).	Change print technology; increase X dimension/magnification factor; re-orientate symbol relative to cylinder engraving angle/screen mesh.

The symbol below is taken from the Calibrated Conformance Test Card and has an engineered low Decodability grade of 50%. As may be determined from the accompanying scan reflectance profile, just to the left of halfway across the symbol, the width of a 2-module bar has been increased in the 6th digit (and since the character is a 1, its Decodability is affected by bar width). Although the original symbol has a very consistent image density, the profile also shows the effect of modulation, most noticeably on the narrow spaces.

Figure 10-2 : Calibration symbol with engineered low Decodability grade and associated Scan Reflectance Profile of symbol with low Decodability character

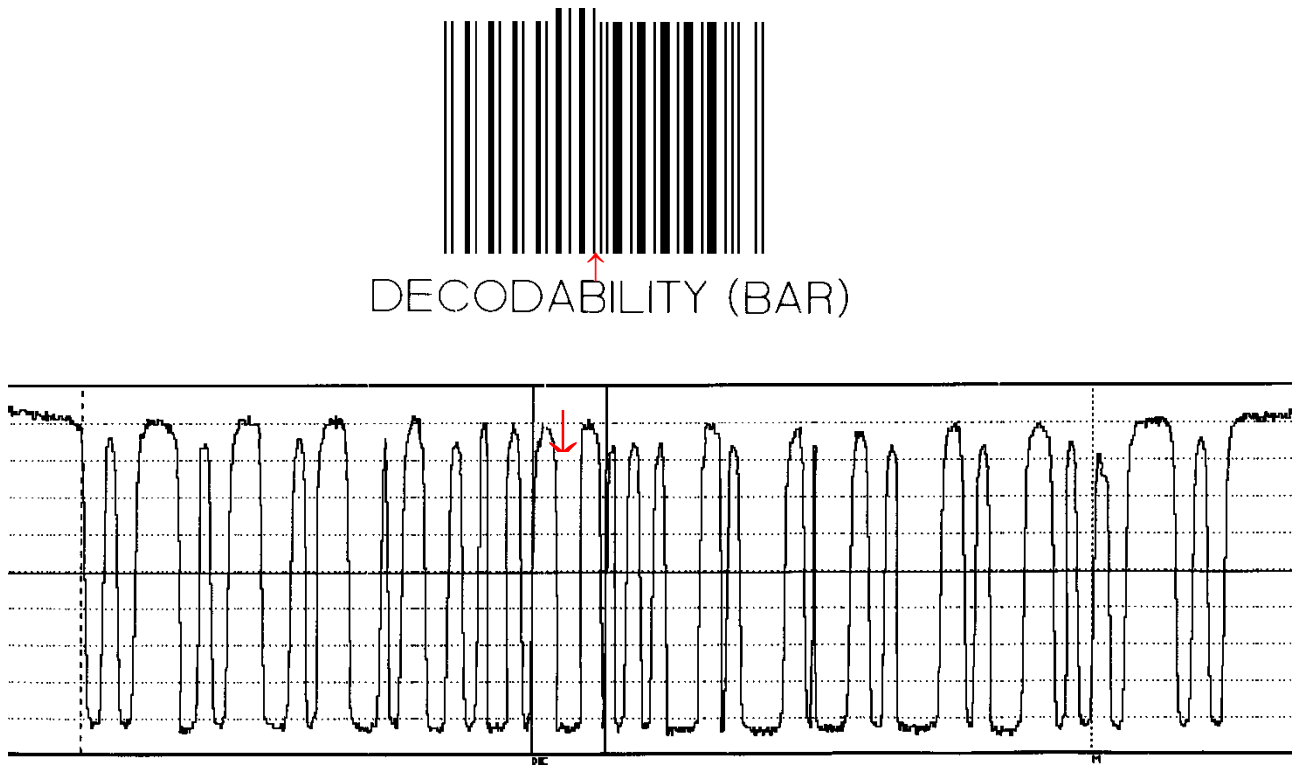

Defects, which show as irregularities in the scan reflectance profile, may be caused by specks of extraneous ink in Quiet Zones or spaces, or by voids in the bars. In symbols printed on recycled or some other materials, local variations in reflectance of the background will also show as defects. The significance of a defect is in direct relation to the depth of the irregularity it causes in the scan reflectance profile.

Common causes and the most likely solutions include:

Cause	Solution
Defective print head elements (thermal printing or ink jet printing) which will tend to produce an unprinted line running through the symbol in the direction of printing.	Clean or replace print head
Satellite ink droplets (ink jet printing).	Clean head, change ink formulation
Haloing (flexography).	Adjust impression pressure and/or ink viscosity
Incorrect matching of thermal transfer ribbons and substrate (poor adhesion of ink to surface).	Use correct ribbon for substrate, use smoother substrate
Measuring aperture too small.	Use verifier with correct aperture, e.g., 0.15 mm (6 mils) for EAN/UPC symbols

The use of a smaller or larger measuring aperture than specified for the symbol in question will produce misleading Defects grades. Too small an aperture will exaggerate the apparent size of a defect; too large an aperture will tend to smooth it out.

The symbol in [Figure 10-3](#) has an engineered defect in a wide element, which shows clearly in the scan reflectance profile. This is similar in appearance, and effect, to a defect caused by a missing print head element.

Figure 10-3 : Calibration symbol with engineered defect and associated Scan Reflectance Profile showing defect

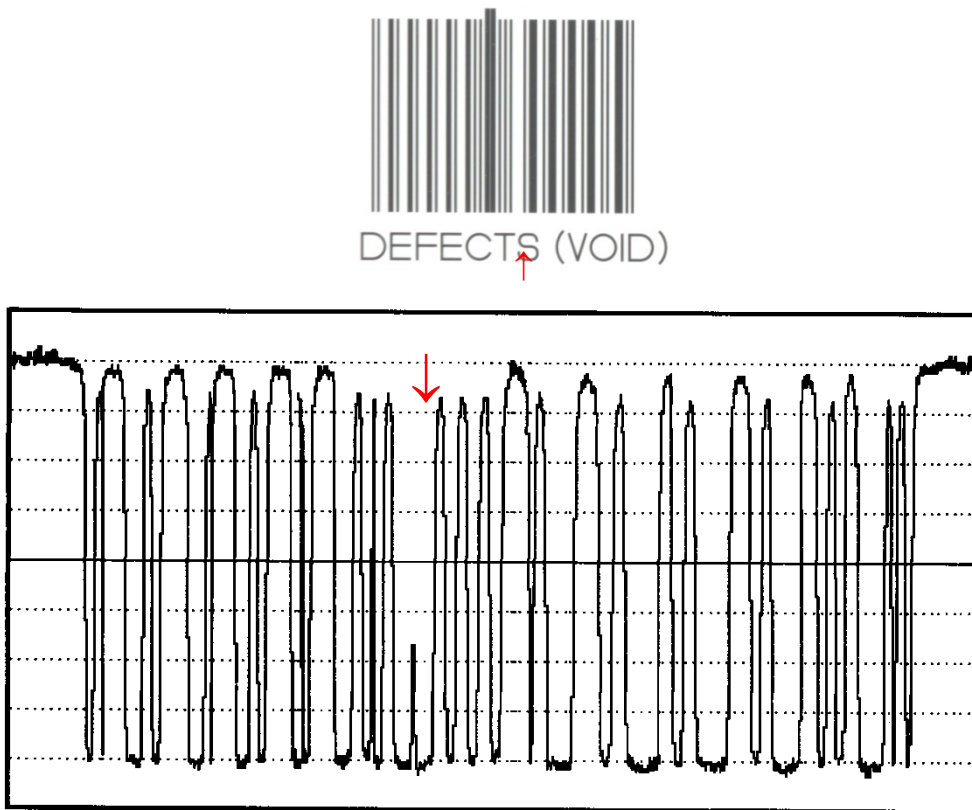

Incorrect **Quiet Zones** are a frequent source of scanning problems. Although the ISO standard does not directly require measurement of the Quiet Zones, it requires "any additional requirements specified by the application specification" to be graded on a pass/fail basis. The *GS1 General Specifications* lay down Quiet Zone requirements for all symbols used in the GS1 System, and a Quiet Zone less than the minimum width will therefore cause the profile grade to fail.

Possible causes of Quiet Zone failure and the remedies are:

Cause	Solution
Printed box surrounding symbol or other interfering print.	Enlarge box; ensure symbol registration to other print allows adequate margins; use light margin indicators if possible
Symbol too close to label edge.	Adjust label feed; reposition symbol farther from edge; use larger label size or smaller symbol

10.2. By printing types

This section is intended as help the interpretation of the verification results from the view of the printing types and the special effects they have on the various GS1 endorsed symbologies. Focused on several different print processes this section gives guidance only.

10.2.1. Contrast in general

Verifiers have different parameters for contrast evaluation. According the Traditional Evaluation a bar and space reflection can be measured. The PCS (Print Contrast Signal) is then calculated from these reflection values. Sometimes it is possible to select between the

worst and best reflection case. The base for the worst case are the reflection values of the minimum Edge contrast (EC_{min}). The base for the best case are the reflection values of the Symbol Contrast (SC).

If the PCS is out of tolerance then the cause is normally the bar or space reflection. For printing the most significant is the bar reflection. According the print process or the materials used it is necessary to increase the space or/and to decrease the bar reflection. A good rule of thumb is PCS at 75 % for any symbology. EAN/UPC Codes have a logarithmic relation between bar and space reflection. This causes variable PCS value limits.

According the ISO evaluation the parameters Edge Contrast, Symbol Contrast, Modulation and R_{min} are defined. Modulation is calculated as ratio of Edge Contrast and Symbol Contrast. The reason for a too low edge contrast can be too low contrast, an irregular print, too wide bars or spaces. Using a overly large measuring aperture will also decrease edge contrast. The edge contrast is also influenced by material characteristics.

The symbol contrast is a value which gives information about the highest contrast in the symbol. If this value is too low then the bar reflection has to be decreased or the reflection of the spaces (background material) has to be increased.

The modulation can be interpreted as regularity of bar or space reflections. If this value is too low then the difference between edge contrast and symbol contrast is too large. Using a higher density of the background colour (or material) should help.

R_{min} should be less or equal than $0,5 * R_{max}$. If this is not the case then the bar reflection is too high. This is often caused unsuitable bar colours or substrate.

10.2.2. Measurements in general

The metric measurement verifies if the width of bar, spaces or combinations are in specification.

The ISO evaluation uses the deviations as base for the calculation of the parameter Decodability. Decodability gives a value of how good a code can be decoded based on metric measurements only. Decodability does not provide the reason for a bad Decodability value. For analysis the Traditional Evaluation based on symbology standards is required.

Before trying to optimize the printing process the film master (pre print) should be verified. An important element is the resolution of a Film Master. A low resolution restricts the size step selection. For all printing systems which use bitmap graphics for transfer to the printer, interpolation problems may cause problems.

10.2.3. Defects in general

Defects are either white dots in bars or black dots in spaces. Defects are caused by bad ink transfer or rough print materials. Depending on printing process different actions can be taken:

High printing:	Change substrate or ink transfer improvement
Flexography:	Increase pressure (not too high to keep metric sizes)
Thermal direct/transfer:	Change label stock, higher temperature, change ribbon, higher pressure, lower printing speed

For defects the aperture of the bar code verifier is important. With increased aperture sizes the defects appear smaller.

10.2.4. Decode in general

This parameter covers Quiet Zones, check digit and element determination. For some symbologies the bar code length will be checked. Errors here are caused by design in pre print phase. Attention should be paid to respecting the correct Quiet Zones.

10.2.5. Bar codes that fail to decode (general)

If a bar code cannot be decoded then it is [very] out of specification. An “expert” visual check will often highlight the cause of the error (missing bar, awful colour combinations, awful print quality, etc).

10.2.6. Thermal printing

Thermal direct contrast

This print process is used by many bar code label printers. Basically a thermal direct print has deep black printed bars but sometimes they only appear deep black to the human eye. For the scanner they usually look somehow grey. To improve the scan the material has to be changed because the reflection value for the bars depends on the thermal sensitive chemicals in the paper. Check that the thermal paper characteristics are fit for the printer. A paper with too high or too low thermal sensitivity may cause problems. Some papers with a very high thermal sensitivity will have higher bar reflection with too much thermal energy. The thermal sensitive chemicals can have green, blue or red as basic colour. Paper with green or blue thermal sensitive chemicals are better suitable than paper with red coloured thermal sensitive chemicals.

So the paper type, thermal sensitivity, chemical type, printer type, printing speed, thermal energy and the print direction will influence the print quality.

Direct thermal does not requiring the use of an inking ribbon but requires coated facestock (typically more expensive than non-thermally coated facestocks) and is very sensitive to temperature, light, water, chemicals and hard use. Direct thermal labels perform best for short term or indoor uses such as products with short shelf lives, shipping or indoor inventory control.

Thermal transfer contrast

It is possible to achieve very good quality bar codes using thermal transfer printing if label and ribbons are compatible. Contrast problems are usually caused by badly adjusted printers or unsuitable combination of label and ribbon (for example paper label and resin ribbon). Contrast will be influenced by heating energy, printing speed and pressure.

A wide variety of thermal transfer ribbons are available and it is very important to match your ribbon selection to the printer. There are three basic formulations of thermal transfer ribbons which are:

- Wax-based ribbons are low in cost and suitable for most applications. Label images may be scratched in use or smear if the temperature is too high.
- Resin-based ribbons produce label images that are much more resistant to wear and extreme conditions. Some resin inks used on certain facestocks can withstand temperatures over 1000 degrees. However, resin-based ribbons tend to be rather expensive.
- Wax-resin ribbons produce label images with higher durability than wax-based ribbons but are lower cost than pure resin based ribbons.

Metric aspects of thermal direct and thermal transfer printing

This type of printer uses a thermal printing head. Each dot is represented by one heating element. The shape of each element is like a square and they are directly neighboured to each other allowing the printing of very clear edges.

Metric problems are often caused by badly adjusted heating. If too hot the bars will get wider because more ink will be transferred.

A bar code with a lot of defects can be caused by an incorrect combination of label and ribbon. Further the printing speed may be too high. If speed reduction does not help another label/ribbon combination should be tested. The bar code can be printed in picket fence or ladder version. Ladder version is more difficult to adjust because the smearing caused by slow cooling increases bar width and not the [uncritical] bar height. Ladder printing has the

advantage that the bar code is still useable if one dot is defective. To improve quality for this case the speed should be reduced and the temperature setting should be adjusted very accurately. The pressure from the print head to the label and ribbon can be adjusted.

10.2.7. Laser printer

Contrast

Laser printer will have problems if the toner is too low or the optical unit has to be replaced. Also the paper stock used may also cause problems if incorrectly matched.

Metric aspect

The black bars are produced by small particles of toner with an irregular size. From a metric point of view these particles have a very irregular shape. In bar code printing this causes blurred edges. If this is a problem then a printer with higher resolution is necessary or the bar code size is adjusted to the printer resolution.

When laser printers are used with some PC operating systems, the software and printer driver combination is not able to use the physical resolution of the printer. In some software bar codes are usually transformed to bitmap graphics. The graphics will then be resized or interpolated by the laser printer to make the graphics fit the printer resolution. For bar code printing this is not suitable. Further dots will often be printed overlapped to get clearer edges. This must be recognised by the Software to get the correct relations between bars and spaces.

10.2.8. Ink Jet printing

Contrast

Ink jet printing causes contrast problems if the substrate absorbency is high (packaging material from recycled content). In the industrial section ink jet printers are in use for direct marking of corrugated paper. The corrugated paper quality varies in a wide range and this causes contrast problems. A more subtle influence is possible by printer adjustment and ink selection.

Metric aspect

Ink jet printing usually prints edges in an irregular shape. This is caused by the paper absorbency and by the irregular shape of the single dots. Improvements can be reached with other paper, by a higher printer resolution or faster drying ink. Also, ink jet head distance, if not kept within the operating parameters recommended by the manufacturer can create fuzzy edges on the bar codes and that lead to problems. Excessive vibration in the line or inconsistent speed can create wavy bar codes. Glue strands and paper dust can clog some of the ink jet nozzles and further impact the quality.

10.2.9. Impact printing

Contrast

This printer type is in principle not good for bar code printing. It is not possible to print straight edges.

Metric aspect

Metric problems using impact printing are also caused by the irregular shape of the single dots. Older printers will wear out and the needle positioning will become less accurate. If problems occur, it is recommendable to think about other printers.

Film-set

This printing type uses a high or very high resolution. Classical errors are here not found. Errors are usually caused by the pre print stage.

10.2.10. High printing (book printing, flexography etc.)

Contrast

Contrast problems here are mostly caused by the paper or the colour combination for bars and spaces. Flexography is often used for printing on corrugated paper or films. Corrugated paper has a rough and brown surface. This causes bad reflectance values for the spaces. On films the background will be printed white and the bars on the white in black. Because of the restricted amount of colour which can be transferred the white density is limited. As a result the packed material will have a big influence to the bar code quality. On film the background white has to be printed 2 or 3 times to get better contrast results.

Metric aspect

The main reason for metric errors in high printing is caused by bar gain. The bar gain increases during the time of use. For bar codes the bar gain has to be recognised by a bar width reduction (BWR). The BWR should be adjusted so that at the beginning the bars are too thin and at end of lifetime (or use time between cleaning intervals) the bars are too thick. Both extremes should be in tolerance. In flexography additionally problems with squashing and moving of bars but these effects can be reduced by a using a Bearer Bar frame around the bar code. Additionally the pressure can be adjusted more precise.

10.2.11. Engraved printing (rotograuve)

Contrast

Contrast problems are caused usually by the selected colour combination. If printed on film the problems are similar as described under Flexography. Engraved printing has the advantage to get more ink on the material.

Metric aspect

Most problems with engraved printing are caused by a too low resolution. The raster resolution should be about 100 lines/cm. If a bar code manufactured by engraved printing is measured then the bar width changes with the position. Sometimes the wide position (dot) and sometimes the valley between dots is too large. Sometimes a small single line in front of a bar can be seen. This causes defects and should be avoided.

10.2.12. Offset printing

Contrast

Offset printing leads to high quality bar codes. Problems may be caused by too little ink or an unsuitable colour combination.

Metric aspect

Offset printing is a precise printing technique. Therefore only low bar gain will appear. For small bar codes (for example EAN/UPC printed at the minimum x-dimension) low bar gain should also be noted.

10.3. By surface types

10.3.1. Corrugated board

Corrugate board (also known as cardboard and fibre board) usually has a brown, textured surface. The brown surface reduces the contrast. The light value of the brown surface can fluctuate greatly from one batch of corrugate to the next. The fibres of the paper produce a surface texture alternating between lighter and darker areas. This may also lead to defects. The surface is normally slightly fluting. If bar codes are printed onto this surface, some bars are more heavily printed at the top of the fluting, making them wider than other bars. Wand verifiers are not well suited to measure on corrugated cardboard. ITF-14 bar codes are particularly suitable for printing on corrugate.

10.3.2. Labels with metal

These labels are paper labels with a thin metal finish. If a bar code is printed on such a label the Symbol Contrast (SC) will be low compared to normal paper labels. The metal finish works like a mirror and darkens the white of the bar code background. If the white background has “holes” then additionally defects will appear.

10.3.3. Film (foil)

There are different types of films available. Some types are clear, others are white or coloured. Some of them have a metal finish like the labels in the previous section.

Clear films require the printing of a white field behind the bar code. Depending on the package content the bar code quality varies in wide range. If the package content is white, yellow, orange or red then these colours will make the white of the bar code background for the scanner appear more white. This improves the Parameter Symbol Contrast (SC) because in the Quiet Zones and wide space reflect more light gets back to the sensor. In narrow spaces, part of the light reflected by the package content will be reflected to the reverse of the neighbouring bars. This light is lost and the contrast for narrow spaces is significantly reduced. The parameter edge contrast and following modulation will be low. To improve the scan the white colour density can be increased. A larger code or a defined bar width reduction to make bars smaller will help.

If the same type of film is used for black, green or blue package content then the Symbol Contrast (SC) will be reduced strongly. This is also valid if behind the bar code is a hollow area. Hollow areas appear as black because no light is reflected. In this case a white background colour with increased density is helpful for quality improvement.

It is difficult to reach Grade 3 for this material type.

10.3.4. Metals (cans)

This material appears to the verifier (and scanner) similar to metallic film or paper labels. If the bar code is printed in picket-fence orientation then the curved shape of the can causes metric problems. Cans that are printed with white background and black bars sometimes have small metal lines visible beside the bars. This leads to defects and should be avoided.

Sometimes, only the white background is printed and the bars are left blank. The blank bars work as a mirror (although they may appear to the human eye as black). This makes scanning results very hard predictable.

10.3.5. Metal films with engraving

Bar coding this material, sometimes used to close yogurt pots for example, should be avoided because the engraving changes the angle in bars and spaces causing the light reflection to be very irregular.

10.3.6. Non-opaque substrates

Account must be taken of possible “show through” of product or other material behind the substrate. To predict scan performance take the following steps:

If the colour of the contents of the packaging is known, verify the symbol quality with the packaging backed by a material of the same colour as the contents. If the colour of the contents is unknown then:

- Perform verification with the symbol on a dark surface
- Perform verification with the symbol on a light surface
- Take the lower of the grades reported as the grade for the symbol.

10.3.7. Glossy substrates

Glossy substrates and/or inks may cause scanning problems if the angle of the symbol surface relative to the scanner causes specular reflection.

11. Using traditional measurements as part of quality

11.1. Print Contrast Signal and tolerances

Traditional measurement has one major advantage for process control purposes, since it provides a measure of element widths relative to the ideal, which can be used for correcting for bar width gain or loss. But bar width deviations, especially systematic across a symbol, do not necessarily correlate well with scanning performance, due partly to the edge to similar edge decoding of the modular symbologies and partly to the tolerant algorithms used in many scanners.

The traditional dimensional "tolerances" - though they were never defined as such in the earlier specifications - were based on arbitrary assumptions and are not directly proportional to the X dimension of the symbol for EAN/UPC symbology.

Contrast measurements based on Print Contrast Signal (PCS) bear a complex relationship to those based on Symbol Contrast. If the light and dark reflectance values (R_L and R_D respectively) on which the PCS calculation method was based were the same as R_{max} and R_{min} , then a fairly simple mathematical relationship would exist. But since the measurement points for R_L and R_D in a PCS calculation may well differ greatly from one verifier to another, it would be risky to place much reliance on extrapolating a Symbol Contrast value from a PCS value.

A further complication is that the minimum PCS for an EAN/UPC symbol varied, depending on the background reflectance value, while for other symbologies it was a single value (usually 75%). However, a few broad conclusions can be drawn, assuming the background reflectance is taken as equivalent to R_{max} and the bar reflectance as equivalent to R_{min} :

- A symbol meeting the traditional minimum PCS requirements will not fail (Grade 0) for Symbol Contrast provided its background reflectance is greater than 30%.
- For EAN/UPC symbols, the minimum PCS values traditionally specified corresponded to a Grade 2 Symbol Contrast for background reflectance (R_{max}) of approx. 50% or higher, but to only Grade 1 Symbol Contrast for materials with a lower R_{max} . In other words, the current minimum quality grade specified of 1.5 excludes a small number of symbols on lower background reflectance materials which just meet the old minimum PCS requirement.
- For ITF-14 symbols printed on corrugated, where the minimum grade for acceptability is 0.5/20/670 virtually all symbols meeting the traditional PCS 75% minimum would also meet this grade requirement.

11.2. Supplementing scan reflectance profile parameter grading with traditional measurements

As has already been stated, the primary advantage of the scan reflectance profile assessment over the traditional element width/PCS measurement is that it provides a far better indication of how well a symbol is likely to perform when read under typical application conditions. But where it falls down is that it is difficult to deduce from the scan reflectance profile grading what specific corrective action needs to be taken to improve quality grades, in terms of aspects that the symbol producer can easily control. Scan reflectance profile grading on its own is of little help for process control purposes.

Direct measurement of bar width gain or loss, is one of the most useful process control tools since it provides the symbol producer with an easily understandable and quantifiable measurement.

12. Considerations for GS1 System symbologies

12.1. Symbologies used in the GS1 System

It is important to remember that ISO verification methodology does not cover all aspects of the GS1 System. Essential features that will have a major impact on the acceptance of a bar code include:

- Symbol Location
- Conformance to the numbering system
- Symbol X dimension and height
- Layout of human readable interpretation
- In line with intended application guidelines (correct symbols)
- Number of symbols
- etc.

Additional visual and/or database checks (for example www.gepir.org for verifying the validity of the GS1 Company Prefix) should therefore be carried out as part of any Quality Control process.

12.1.1. EAN/UPC Symbology

The main characteristic of this symbology affecting verification is the different treatment of the three sets of symbol characters for the digits 1, 2, 7 and 8. The reference decode algorithm uses the combined width of both bars in these characters to discriminate between a 1 and a 7, and between a 2 and a 8, which are "ambiguously decodable" since they share the same set of edge to similar edge modular dimensions. The addition to, or subtraction from, the element widths of 1/13 module in the symbol characters for the digits 1, 2, 7 and 8 is intended to increase the differences between the sums of the bar widths for each pair of ambiguous characters. The Decodability parameter for these characters takes account of bar width gain and loss whereas it does not for the remaining symbol characters. The consequence is that a symbol not containing any of these four symbol characters may suffer substantial bar width gain or loss without degrading its Decodability, whereas a symbol which does contain one or more of them is likely to have a lower Decodability grade, with the same amount of bar width gain or loss. However, the laws of probability suggest that only some 6.9% of symbols would not be affected by this, so it is wise to err on the side of caution and assume that bar width growth or loss is a possible cause of a poor Decodability grade for EAN/UPC symbols. It is also wise (for process control purposes) not to assume that the Decodability grade correlates with bar width deviation, but it is far safer, and easier, to rely on the traditional measurement of bar width deviation for adjusting the production process.

The measuring aperture for EAN/UPC symbols ([Figure 12-1](#)), irrespective of magnification, is 0.15 mm (6 mils). This is not one of the four default aperture sizes recommended in the ISO standard, which are 3, 5, 10 and 20 mil, but is usually available from verifier manufacturers. This diameter was based on measurement of symbols with various apertures and much test scanning in order to determine which aperture gave results correlating best with scanning performance.

Figure 12-1 : EAN/UPC Symbols

EAN-13	UPC-A	EAN-8	UPC-E

12.1.2. GS1-128 Symbology

Apart from print quality, which is assessed in the standard way, the formatting of GS1-128 symbols should be checked visually from the information output by the verifier.

GS1-128 is an edge-to-similar edge decodable symbology, but its reference decode algorithm also requires a check of the sum of the widths of the three bars in each character, as part of its parity checking process. Consequently its Decodability is affected by bar width gain or loss.

Measuring apertures for GS1-128 symbols vary according to the area of application and X dimension. For all applications except the GS1 Extended Coupon Code, which is used only in North America, an aperture of 0.25 mm (0.010 inch) is specified, giving a minimum acceptable grade of 1.5/10/670.

Data contained in GS1-128 symbols must be formatted according to the rules in the *GS1 General Specifications* for the use of Application Identifiers. Specific features to check are:

- Presence of FNC1 in the first position after the start character has been reserved exclusively to indicate GS1-128
- Use of FNC1 as a field separator between variable length AI data fields
- Sequencing of Application Identifiers, with fixed length Application Identifiers preceding variable length ones
- Length of data fields with fixed length Application Identifiers
- Correct formatting of data in all AI fields
- Absence of encoded parentheses around Application Identifiers.

The extent to which a verifier can do this automatically will varies, even for those which have GS1-128 as a specific symbology option.

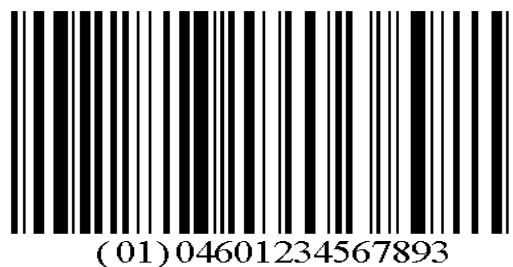
Figure 12-2 : GS1-128 Symbol

12.1.3. ITF-14 Symbols

This symbology is a two-width (narrow/wide) symbology that cannot be decoded by the edge to similar edge technique, but all element widths must be measured. It is, therefore, more susceptible to the problems caused by bar width gain or loss.

The standard ISO verification technique is fully applicable to ITF-14. However, the *GS1 General Specifications* state that additional checks must be made to ensure that the X dimension is within the permitted range and guidelines for automated scanning systems, since many packages carrying the ITF-14 symbol (see Figure 12-5) will be read on unattended automatic conveyor systems.

Measuring apertures for the ITF-14 symbol are 0.25 mm (10 mils) for symbols with an X dimension up to 0.635 mm (0.025 inch) and 0.50 mm (20 mils) for symbols with an X dimension larger than 0.635 mm (0.025 inch).

The minimum acceptable grade for symbols printed with the higher range of X dimension is 0.5/20/670. This 'low' overall symbol grade was selected because the brown corrugated substrates on which such symbols are often printed typically have a reflectance value below 40%, and sometimes even below 30%, and cannot therefore ever achieve a Symbol Contrast better than 40% (the lower threshold for a Grade 2 Symbol Contrast) no matter how dense the ink and how well the other attributes of the symbol are graded. As a result the scan reflectance profile grade will most often be dictated by Symbol Contrast, so cannot be higher than 1 for symbols on these materials, giving a maximum achievable overall symbol Grade of 1.0.

Such symbols may also be affected by the inherent noise in the background reflectance caused by the substrate's composition, which may well lead to reduced Defects grades and possibly also low Edge Contrast and Modulation values. It is therefore desirable to ensure that symbols printed on these corrugated materials are of as high a quality as possible in respect of the other parameters.

Figure 12-3 : ITF-14 Symbol

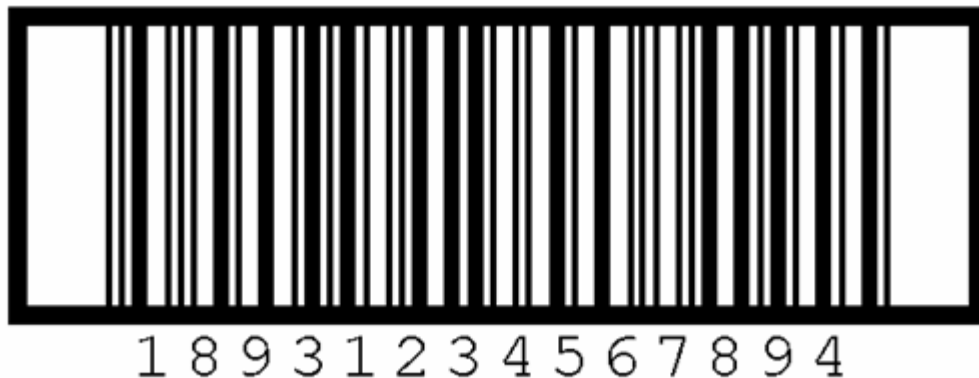

12.1.4. GS1 DataBar

GS1 DataBar is a family of linear barcodes capable of encoding the 14-digit Global Trade Item Number (GTIN). GS1 DataBar is designed to bring the benefits of full product identification, as well as other supply chain applications, to space-constrained situations where existing linear symbologies could not normally be used. The International Standard *ISO/IEC 15416 Automatic identification and data capture techniques – Bar code print quality test specification – Linear symbols* methodology should be used for measuring and grading the GS1 DataBar (formerly RSS) family of symbols. For more information see the *GS1 General Specifications* Section 5.6 - Linear Bar Codes – GS1 DataBar (Formerly RSS)

Figure 12-4 : GS1 DataBar Omnidirectional Symbol



12.1.5. Other GS1 Symbologies

GS1 endorse two non-linear bar code symbologies: Data Matrix (ISO version ECC 200) and Composite Symbology. Verification of these non-linear bar codes requires some additional parameters that are not within the scope of this manual. For more information see the *GS1 General Specifications* Section 5.7 – Two Dimensional Bar Codes – GS1 DataMatrix Symbology.



ANNEX A. Grade thresholds for scan reflectance parameters

Scan Reflectance Profile, with key measurements indicated, and grade thresholds for each parameter:

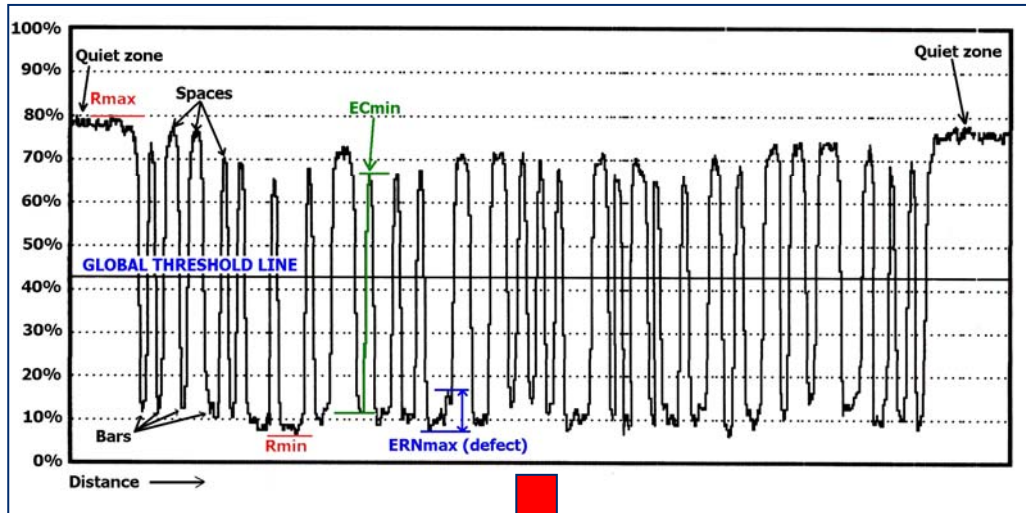

Grade	Decode	Symbol contrast	Min. reflectance	Edge contrast	Modulation	Defects	Decodability
4	Good	$\geq 70\%$	$\leq 0,5_{R_{max}}$	$\geq 15\%$	$\geq 0,70$	$\leq 0,15$	$\geq 0,62$
3	-	$\geq 55\%$	-	-	$\geq 0,6$	$\leq 0,20$	$\geq 0,50$
2	-	$\geq 40\%$	-	-	$\geq 0,5$	$\leq 0,25$	$\geq 0,37$
1	-	$\geq 20\%$	-	-	$\geq 0,4$	$\leq 0,30$	$\geq 0,25$
0	Fail	$< 20\%$	$> 0,5_{R_{max}}$	$< 15\%$	$< 0,4$	$> 0,30$	$< 0,25$

ANNEX B.

Use of Calibrated Conformance Standard Test Card

The Calibrated Conformance Standard Test Cards are produced to an extremely high degree of accuracy and the pricing from reflects the high cost of production.

The Calibrated Conformance Standard Test Cards assist in determining if an ISO/IEC 15426-1 based bar code verifier is operating within the manufacturer's published operating tolerances. Additionally, the Calibrated Conformance Standard Test Card can also function as a guide or training tool in the proper operation of the verifier to assure that the verifier/user combination is providing accurate and repeatable verification results as published by the manufacturers.

Procedures For "Calibrated Conformance Standard Test Card" Use:

The following tests should be performed on a regular basis. The frequency of this testing should adhere to your standard internal quality procedures for quality control equipment calibration / correlation testing. If such procedures do not exist, contact the manufacturer of your verifier for its recommendation. At the minimum, these procedures should be performed any time there is a concern for the operating condition of your verifier or the results gathered by a particular operator.

Follow the manufacturer's recommended procedure for set up, programming, normal operational calibration and use of the verifier prior to performing any tests.

It is important to note that improper use of the verifier through incorrect set up and/or calibration can cause misleading results. It is imperative that the operator follows the manufacturer's procedures for calibration of the verifier. Calibration at a frequency greater than recommended may assure higher accuracy and repeatability.

Care should be taken in the selection of the location where verification is performed. The operator should be aware of unusual ambient light conditions that may affect readings, such as uneven lighting. Additionally, the above mentioned calibration of the device should be performed under the same ambient lighting conditions as those where the testing will be performed.

Operator proficiency can influence the results. Operators must be trained in consistent operation and care should be taken in all testing situations. Bar code verification should be approached the same as any other quality control or quality monitoring function. Practise using the manufacturer's procedure to obtain the proper combination of control, technique and verifier/operator "interface". The goal is to obtain consistency of technique when verifying the bar code.

ISO/IEC -15416 standards specify ten (10) scans of a symbol are required to obtain a proper "Symbol Grade". Though the Calibrated Conformance Standard Test Cards are made to a level of accuracy and repeatability that exceeds more commonly produced bar codes, it is still recommended that the test described here be based upon ten (10) scans. The ten (10) scan average value for each of the quality parameters under test should match the recorded value on the Test Card taking into account the verifier manufacturer's published specifications and tolerances.

If the test results agree with the recorded value on the card, within the tolerance range of the manufacturer, then the verifier/user combination is considered acceptable and operating properly. If the results do not yield the correct value (again, taking into account the manufacturer's published tolerances), then the test should be repeated. If, after repeating the test, the results still do not fall within the manufacturer's stated tolerances then verifier or operator must be considered suspect. If you are assured that the operator's technique is consistent and controlled and the above test results are still not within the allowable range,

you should contact the manufacturer of the equipment for resolution (repair, factory adjustment or recalibration, etc.).

Figure 12-5 : Calibrated Conformance Standard Test Cards

CALIBRATED CONFORMANCE STANDARD TEST CARD

ITF-14 (Interleaved 2-of-5)
(for Use with 20 mil Apertures Only)

Interleaved 2-of-5 Master Grade



00614141012343

DEFFECTS (SPOT) _____ %



LOW DECODABILITY: _____ %



CONTRAST: _____ %

DECODABILITY: _____ %
CONTRAST: _____ % Rmin: _____ %
MODULATION: _____ % Rmax: _____ %

GS1 DataBar Expanded Master Grade
(Also applicable for GS1 Databar Expanded Stacked)



(01) 00614141012343

GS1 DataBar Limited Master Grade



(01) 00614141012343

DECODABILITY: _____ %

GS1 DataBar Omnidirectional Master Grade
(Also applicable for GS1 Databar Stacked, Stacked Omnidirectional and Truncated Symbols)



(01) 00614141012343

DECODABILITY: _____ %



DEFFECTS (VOID) _____ %



LOW DECODABILITY: _____ %



CONTRAST: _____ %

CALIBRATION # _____
WAVE LENGTH: 670 nm
EFFECTIVE APERTURE: 0.006 in. (0.150 mm)

BarCodes and eCom™
US

PART NO. CCSV-DB REV C

* ALL SYMBOLS PRINTED AT THE SAME X DIMENSION OF 833 IN (20.925 mm)
 * PER ANSI A393 & ISO/IEC 16498 STANDARDS
 DATE ISSUED: _____
 THIS STANDARD IS CERTIFIED FOR 3 YEARS FROM IN SERVICE DATE WHEN HANDLED IN ACCORDANCE WITH USE OF CALIBRATED CONFORMANCE STANDARDS DOCUMENTATION.
 © 2007 GS1 US. ALL RIGHTS RESERVED.

CALIBRATED CONFORMANCE STANDARD TEST CARD

GS1-128 Master Grade



(00) 006141411234567890

DECODABILITY: _____ %
CONTRAST: _____ % Rmin: _____ %
MODULATION: _____ % Rmax: _____ %

DEFFECTS (SPOT) _____ %



LOW DECODABILITY: _____ %



CONTRAST: _____ %

CALIBRATION # _____
WAVE LENGTH: 670 nm
EFFECTIVE APERTURE: 0.010 in. (0.250 mm)

BarCodes and eCom™
US

PART NO. CCSV-128 REV B

* ALL SYMBOLS PRINTED AT THE SAME X DIMENSION OF 20 IN (508.000 mm)
 * PER ANSI A393 & ISO/IEC 16498 STANDARDS
 DATE ISSUED: _____
 THIS STANDARD IS CERTIFIED FOR 3 YEARS FROM IN SERVICE DATE WHEN HANDLED IN ACCORDANCE WITH USE OF CALIBRATED CONFORMANCE STANDARDS DOCUMENTATION.
 © 2008 GS1 US. ALL RIGHTS RESERVED.

ANNEX C.

The process of symbol generation

1. Generating the Input Data
2. Symbol generation
3. Developing the Master Film
4. Direct Printing
5. Further Processing, Film Developing (for traditional printing technologies)
6. Film editing
7. Plate developing (Printing plate)
8. Proof printing
9. Printing
10. Quality control after printing
11. Impression (repeated printing) (Steps 4-8, 5-8, 6-8)

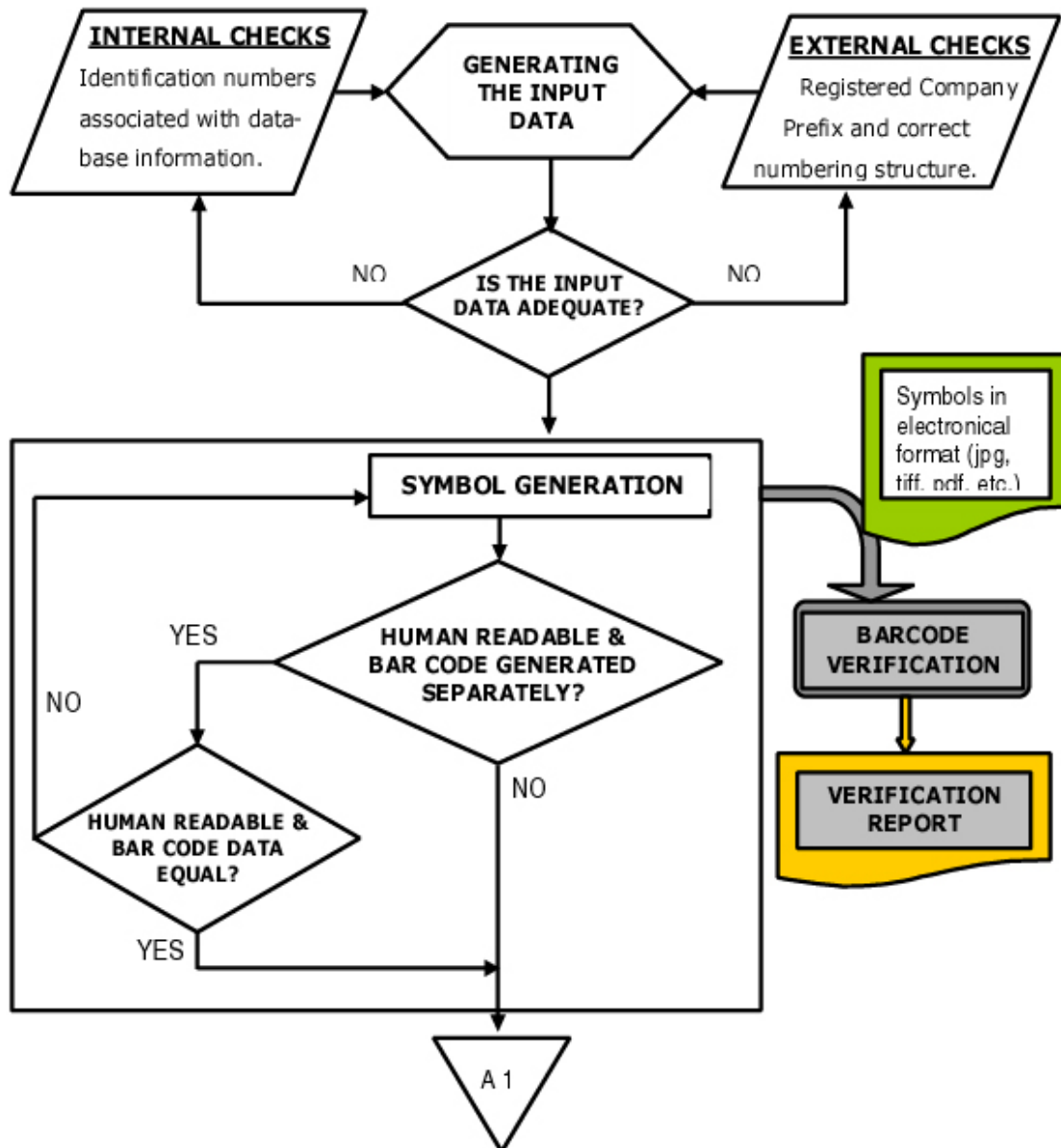

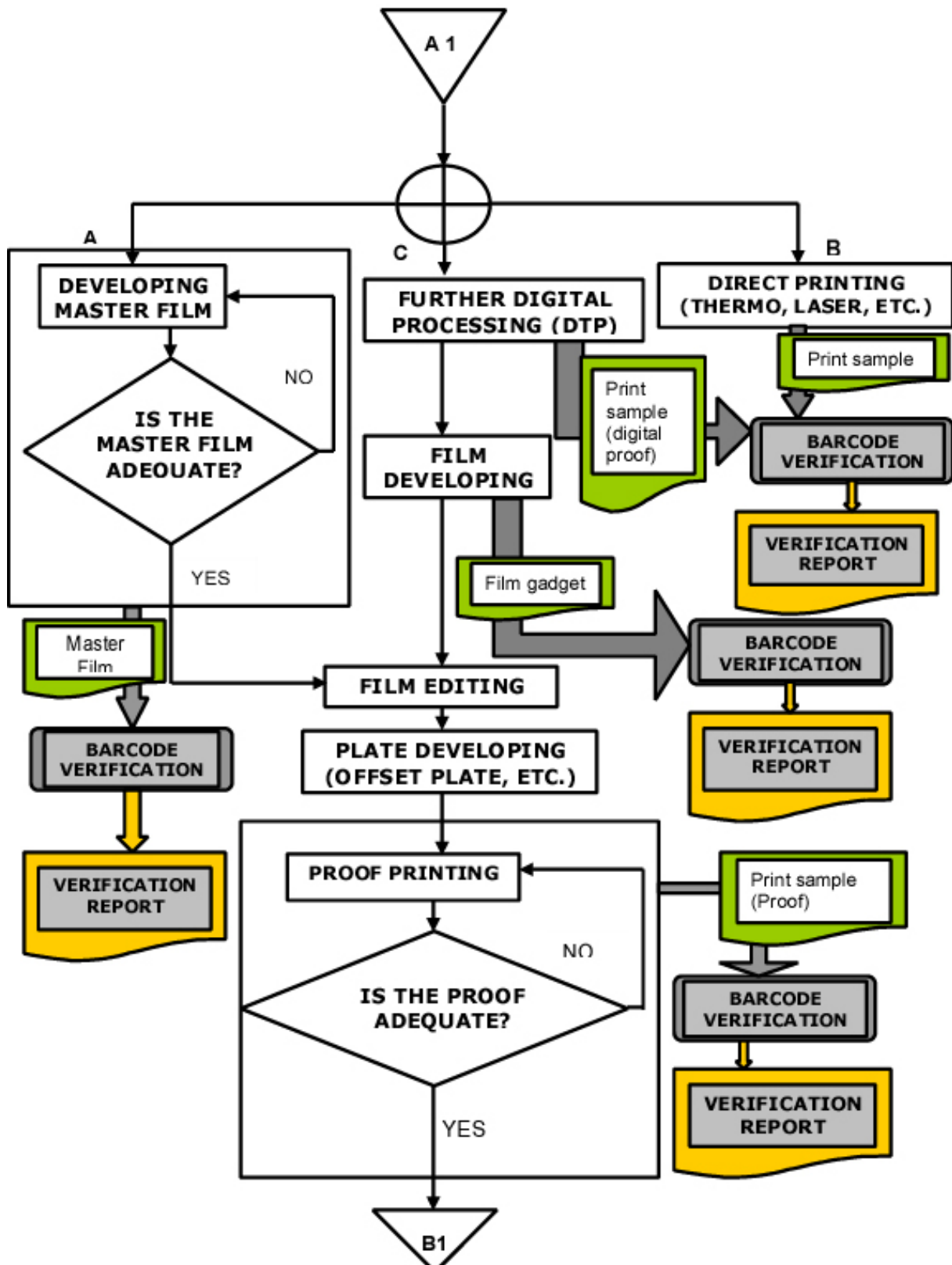

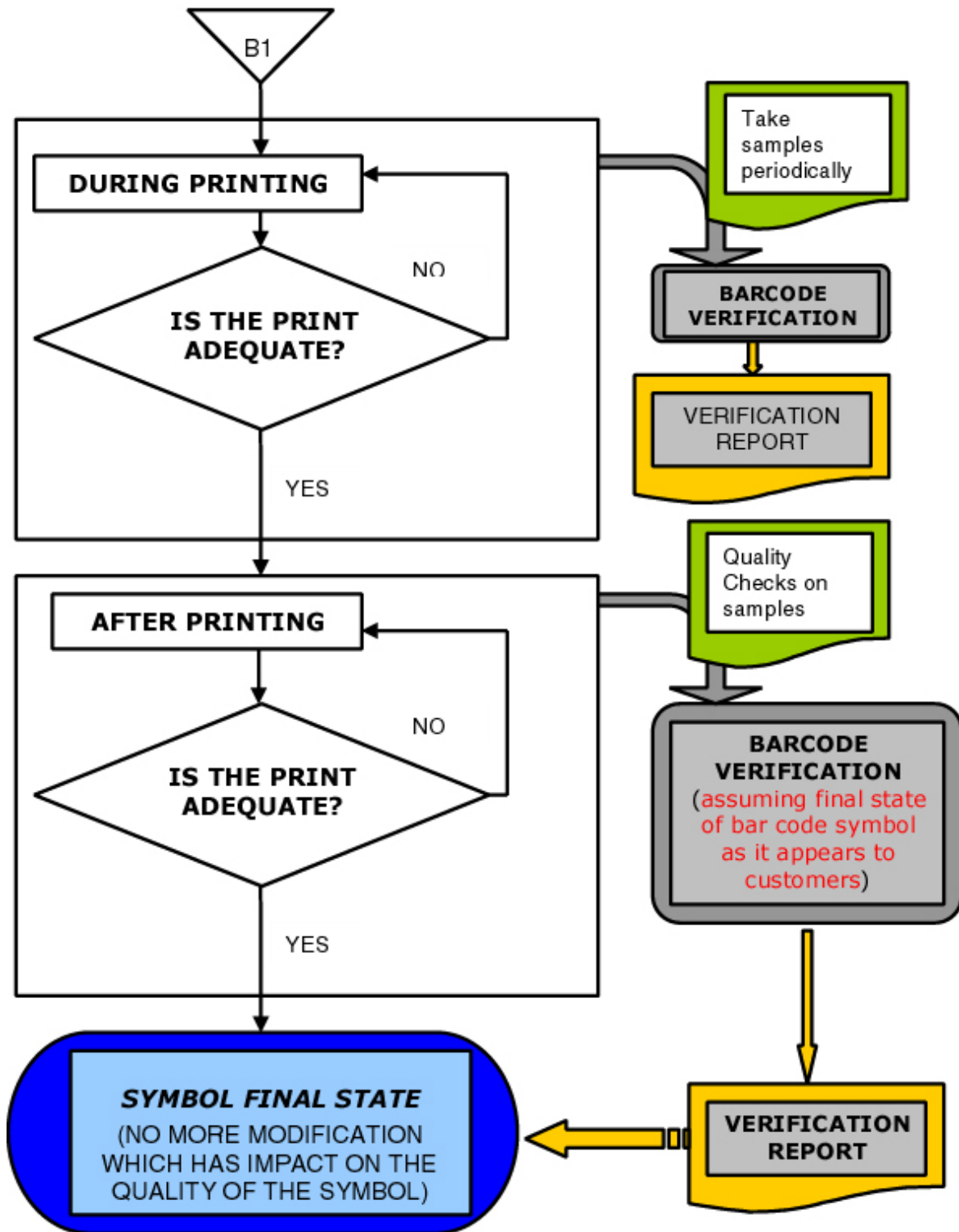

ANNEX D.

GS1 Bar Code Verification Template

Introduction

This GS1 Bar Code Verification Template was developed in co-operation with retailers, manufacturers, logistic providers and equipment providers to ensure a common reporting approach on a global level. This helps ensure consistency regardless of where and by whom the symbols are tested thus removing the costly and inefficient requirements for multiple testing of identical symbols and reducing the cost of compliant equipment.

This template does not introduce any requirements in and of itself. The sole aim is to provide a common reporting format to measure compliance with the numbering and bar coding standards of GS1 laid down in the *GS1 General Specifications*.

Background

GS1 has developed this verification template on the basis of ISO/IEC 15416 Bar Code Print Quality Test Specifications for Linear Symbols. This not only allows for assessing the quality of printed bar code symbols but also checks against other key aspects of GS1 System (symbol location, fit-for purposes, data integrity, etc).

A GS1 initiated Verifier Conformance Testing Project was conducted because of concerns expressed that different verifiers or verification services were unable to perform consistently. The perception was that different verifiers gave substantially different results when measuring the same symbol. A precisely defined test programme was performed under the auspices of GS1 and concluded that:

- All verifiers tested (each one ISO compliant) demonstrated the capability of consistent performance.
- Operators of verifiers require proper training and instruments require regular calibration in accordance with manufacturer recommendations.
- Most verifiers tested were capable of conforming to GS1 requirements

It is therefore important to stress the need for professional verification services and that bar code print quality should be integral part of an overall quality programme. Section 5.4.2.8 provides a quick reference list of symbol quality specifications depending on the symbol type, the application, or the identification number the symbol is carrying.

All GS1 user companies should perform quality control of bar code production and most GS1 Member Organisations offer a verification service. This report template may be used by any organisation or company as part of a quality programme while respecting the Copyright of the GS1 logo (or any heading or text that imply actual GS1 endorsement (subject to local licensing agreements such as accreditation programmes, which may allow exceptions)).

The template below highlighting critical issues relating to verification and provides a common template for reporting on the most common areas of application. In itself it is not a guarantee of scan performance and nor does it cover all applications of the GS1 Systems (e.g., GS1 DataMatrix).



Product Description: <Brand and Name of Product>
Type of bar code: <Symbol Type>
Data encoded: < Data Encoded>
Print Method: <Print Method>
Number of bar codes on product: <Number of Symbols>

- Please Note:
- These assessments are based on meeting the minimum GS1 standards.
 - To ensure efficient scanning, the bar code should exceed the minimum.

Testing Summary

<i>The GS1 General Specifications for Linear Symbols tested environments:</i>	
<i>1) Omni-directional Retail Point of Sale (POS)</i>	<i>PASS or FAIL or Not assessed</i>
<i>2) General Distribution (Automated scanning in Supply Chain)</i>	<i>PASS or FAIL or Not assessed</i>
<i>2.1) GS1 Logistic Label (SSCC)</i>	<i>PASS or FAIL or Not assessed</i>
<i>3) General Purpose Hand Scanning</i>	<i>PASS or FAIL or Not assessed</i>
<i>Complies to GS1 Symbol Location Recommendations</i>	<i>In/Out Spec (& comment on business critical issue)</i>
<i>ISO Symbol Grade</i>	<i>ISO <x.x>/06/660 (0.0 – 4.0) PASS/FAIL</i>
Business Critical Comments	

Technical Analysis of Symbol

GS1 Parameters	Comment Reference	Assessed	Within Standard Range	Required
Symbol Structure ¹			✓	(dependent on symbol encoded)
X-dimension ² (magnification)		0.330	✓	0.264mm-0.660mm
Bar Code Height		26mm	✓	26.04mm
Quiet Zone (Left)			✓	3.63mm
Quiet Zone (Right)			✓	2.31mm
Human Readable			✓	One-to-one match with bar code data
Bar Code Width			✓	<165mm
Validity of GS1 Company Prefix			✓	
Data Structure			✓	(dependent on structure encoded)

ISO Parameters	Comment Reference	Grade ISO/ANSI	Within Standard Range	Required
Overall ISO Grade ³		3.8/06/660	✓	>1.5
Decode		4.0	✓	>1.5
Symbol Contrast		3.8	✓	>1.5
Minimum Reflectance		4.0	✓	>1.5
Edge Contrast		4.0	✓	>1.5
Modulation		4.0	✓	>1.5
Defects		4.0	✓	>1.5
Decodability		4.0	✓	>1.5

Note 1 Includes Check Digits, ITF-14 wide-to-narrow ratio, etc.

Note 3 0.5 acceptable for ITF-14 with x-dimension ≥ 0.635 mm

Note 2 Information on conversion between ISO & ANSI and X-dimension & Magnification Factors is on the website:

<http://www.gs1.org/productsolutions/barcodes/support/>

Additional Tests	ISO Symbol Grade (0.0 - 4.0) PASS/FAIL	General Comment
GS1-128 Application Identifiers encoded – See comments		Pass/Fail/Not assessed
(example) Multiple GS1-128 symbols - Row 2		
(example) Multiple GS1-128 symbols - Row 3		
Educational Comments		

Notes (informative localised)

- It is the responsibility of the brand owner to ensure the correct use of the GS1 Company Prefix and the correct allocation of the data content.
- Rejection of products should not necessarily be based only on an out of specification results
- Bar Code verifiers are measuring devices and are tools that can be used for assisting in quality control. The results are not absolute in that they do not necessarily prove or disprove that the bar code symbol will scan.
- This report may not be amended after issue. In the event of a dispute over contents the version held at [TESTING AGENCY] will be deemed to be the correct and original version of this report.

Important Note (normative localised)

This Verification Report may contain privileged and confidential information Intended only for the use of the addressee named above. If you are not the intended recipient of this report you are hereby notified that any use, dissemination, distribution or reproduction of this message is prohibited. If you received this message in error please notify [TESTING AGENCY].

Disclaimer (legal localised)

This report does not constitute evidence for the purpose of any litigation, and [TESTING AGENCY] will not enter into any discussion, or respond to any correspondence in relation to litigation. Every possible effort has been made to ensure that the information and specifications in the Bar Code Verification Reports are correct, however, [TESTING AGENCY] expressly disclaims liability for any errors.

ANNEX E.

Selecting a Verifier

GS1 is often asked for advice on the selection of equipment. Whereas GS1 is commercially impartial the following informative information is provided.

ISO/IEC 15416 Compliant?

Compliance with this standard is a pre-requisite.

Consistency of performance?

GS1 initiated a Verifier Conformance Testing Project because of concerns expressed in certain areas of the market place that verifiers were unable to perform consistently. The perception was that different verifiers gave substantially different results when measuring the same symbol. A precisely defined test programme was performed under the auspices of GS1 and concluded that:

- All verifiers tested demonstrated the capability of consistent performance.
- Operators of verifiers require proper training and instruments require regular calibration in accordance with manufacturer recommendations.
- Most verifiers tested were capable of conforming to GS1 requirements.
- No major difference in accuracy was noted between hand-held and automatic scanning, but automatic scanning gave a somewhat narrower spread of results.

Will the primary use of the verifier be for monitoring production?

If the verifier will be used in the press-room, a simpler verifier able to give indications of bar width gain or loss may be sufficient - either by means of LEDs which show in broad steps how much gain or loss is occurring and in which direction, or by displaying the data in numerical form.

Is a printout of the data required?

If the verifier is to be used by Quality Control personnel, a more detailed analysis of both quality grades and traditional bar width gain/loss measurements will be required. The unit should almost certainly incorporate either a printer or means of downloading data for record-keeping and trend analysis.

Will the primary use of the verifier be to check that the finished symbol meets customer requirements?

This may be in the manufacturer's premises, on the packaging line or in the warehouse; it may be at an intermediate distribution point; or it may be in the customer's receiving operation. In such cases the primary need is for a report of overall symbol grade. In addition reporting of parameter grades is useful. The ability to provide a permanent record of results is highly desirable, both as evidence of compliance and in order to assist subsequent analysis of symbol characteristics.

Is film master verification required?

In the special case of film master verification, both the construction of the device (ability to measure by transmitted light) and its measurement accuracy (which ideally needs to be ± 2.5 microns) are of equal importance.

What type of verifier?

There are many types of verifier, and almost as many ways of categorising them, but for practical purposes it is most convenient to group them into two classes, related to where they are to be used and the extent to which all their possible functions are required.

The first group, often referred to as "Class A", contains the "full-function" type of verifier, is well suited to a Quality Control laboratory. Class A verifiers performs a full range of measuring functions and provides comprehensive analytical reports on the symbol, enabling the cause of problems to be diagnosed. Its use requires a good degree of knowledge of the technology and the operator must therefore be specially trained. Its measurement accuracy may be substantially higher than the average; its cost almost certainly is, and the time taken to perform the necessary scans and output the results may be relatively long – but in the expected conditions for which such an instrument is purchased this is unlikely to be a problem. This type of verifier may have motorised optical heads to improve the evenness of movement, or be based upon camera technology, to achieve the multiple scanning requirements, and to enable accurate dimensional measurements to be performed; they may have interchangeable measuring apertures and light sources to enable measurement of symbols with a wide range of X dimensions and meeting the illumination needs of differing application standards. Certain Class A instruments are intended to be used in conjunction with a personal computer with special verification software for the symbol analysis and display/printing of results, linking to databases, etc.

The second group, often referred to as "Class B", contains all the simpler easy-to-use devices, intended for use in the pressroom or on the receiving dock by relatively less well-trained operators. At their simplest they are used just to check rapidly that the symbols are of the desired grade or better, and – particularly in the pressroom - to obtain an indication of bar width gain or loss and of contrast to help the press operator to fine-tune his machine. Typically they have a single light source and measuring aperture, though by the use of plug-in wands or mice a degree of interchange-ability may be achieved. Some instruments use laser beam illumination which facilitates multiple scans of the symbol, though the effective measuring aperture may not be circular in shape and its size may not be precisely known; they may also be more limited in their reflectance measurements.

There is a group of specialised verifiers designed for mounting on printing equipment - some are designed for high-speed presses, others for on-demand printers - which monitor the bar codes produced by the equipment and provide continuous analysis of key parameters, notably element widths, to enable the operator to control the printing process very speedily. Some of these devices are even able to feed back control instructions automatically to improve symbol quality and reprint defective labels.

A particular verifier may be hard to fit neatly into either class, but whatever the prime purpose of the verifier, checking the features below will help to determine the suitability of manufacturers' products for the particular need. There will almost certainly be a **relationship between the features supported and the price** of the instrument. If budgets are restricted, over-specification of the instrument should be avoided. Equally, under-specification will only lead to frustration:

- Does the verifier support the ISO/IEC methodology?
- Has the verifier been tested for conformance with ISO/IEC 15426-1?
- What is the optical arrangement (wand, mouse, motorised head, etc)?
- What wavelength light source does it use? The *GS1 General Specifications* require 670 nm ± 10 nm.
- What measuring aperture(s) is/are available? Different apertures from the set (6 mils, 10 mils, 20 mils) are called for depending on the symbols tested and intended application.
- What form of output is available (e.g., LEDs, display, printout of details and individual scan profiles, PC connection, etc.)?
- Is it portable or does it require a fixed location?

- Can it perform scan averaging (to meet the 10 scan requirement)?
- Does it provide traditional measurement of bar width gain/loss?
- What symbologies is it capable of verifying?
- Does it support GS1-128 specifically (or merely the Code 128)?

Useful contacts:

AIM (Association for Automatic Identification & Mobility) is the global association of companies providing equipment and supplies for the automatic identification market. They maintain a classified list of members in the form of a web based Buyer's Guide.

Association for Automatic Identification and Mobility (AIM):

Web: <http://www.aimglobal.org/>

Other useful web-addresses	
<p>AXICON Web: www.axicon.com</p> <p>DATAMAX Web: www.datamaxcorp.com</p> <p>HAND HELD PRODUCTS Web: www.handheld.com</p> <p>LABEL VISION SYSTEMS Web: www.lvs-inc.com</p>	<p>REA ELEKTRONIK Web: www.rea-elektronik.net</p> <p>RJS a division of PRINTRONIX Web: www.printronix.com</p> <p>STRATIX CORPORATION Web: www.stratixcorp.com</p> <p>WEBSCAN Web: www.webscaninc.com</p>

ANNEX F.

Glossary of terms

Add-On Symbol	A bar code used to encode information supplementary to that in the main bar code.
aperture	A physical opening that is part of the optical path in a device such as a scanner, photometer, or camera. Most apertures are circular, but they may be rectangular or elliptical.
auxiliary guard patterns	Components of the EAN/UPC Symbology. The centre guard bar pattern, the left guard bar pattern, and the right guard bar patterns that are represented in some of the symbols are specific types of auxiliary guard pattern.
bar gain/loss	The increase/decrease in bar width due to effects of the reproduction and printing processes.
Bearer Bars	Bar abutting the tops and bottoms of the bars in a bar code , or a frame surrounding the entire symbol, intended to equalize the pressure exerted by the printing plate over the entire surface of the symbol and/or to prevent a short scan by the bar code reader
brand owner	The party that is responsible for allocating GS1 System numbering and bar code symbols on a given trade item. The administrator of a GS1 Company Prefix.
Check Digit	A final digit calculated from the other digits of some GS1 Identification Keys. This digit is used to check that the data has been correctly composed. (See http://www.gs1.org/barcodes/support/check_digit_calculator)
concatenation	The representation of several Element Strings in one bar code.
data titles	Data titles are the abbreviated descriptions of data fields which are used to support manual interpretation of bar codes.
direct print	A process in which the printing apparatus prints the symbol by making physical contact with a substrate (e.g., flexography, ink jet, dot peening).
EAN/UPC Symbology	A family of bar codes including EAN-8, EAN-13, UPC-A, and UPC-E Bar codes. Although UPC-E Bar codes do not have a separate symbology identifier, they act like a separate symbology through the scanning application software. See also EAN-8 Bar code, EAN-13 Bar code, UPC-A Bar code, and UPC-E Bar code.
EAN-13 Bar Code	A bar code of the EAN/UPC Symbology that encodes GTIN-13, Coupon-13, RCN-13, and VMN-13.
EAN-8 Bar Code Symbol	A bar code of the EAN/UPC Symbology that encodes GTIN-8 or RCN-8.
Element String	The combination of a GS1 Application Identifier and GS1 Application Identifier Data Field.
fixed length	Term used to describe a data field in an Element String with an established number of characters.
Fixed Measure Trade Item	An item always produced in the same pre-defined version (e.g., type, size, weight, contents, design) that may be sold at any point in the supply chain.
Function 1 Symbol Character (FNC1)	A symbology character used in some GS1 data carriers for specific purposes.
General Distribution Scanning	Scanning environments that include bar coded trade items packaged for transport, logistic units, assets and location tags.

Global Trade Item Number (GTIN)	The GS1 Identification Key used to identify trade items. The key comprised of a GS1 or U.P.C. Company Prefix followed by an Item Reference Number and a Check Digit.
GS1 Application Identifier	The field of two or more digits at the beginning of an Element String that uniquely defines its format and meaning.
GS1 Check Digit Calculation	A GS1 System algorithm for the calculation of a Check Digit to verify accuracy of data.(e.g.: Modulo 10, Price check digit).
GS1 Company Prefix	Part of the GS1 System identification number consisting of a GS1 Prefix and a Company Number, both of which are allocated by GS1 Member Organisations.
GS1 DataBar (formerly RSS)	A family of bar codes, including GS1 DataBar Truncated, GS1 DataBar Limited, GS1 DataBar Expanded and GS1 DataBar Stacked. Any member of the GS1 DataBar family can be printed as a stand-alone linear symbol or as a composite symbol with an accompanying 2D Composite Component printed directly above the GS1 DataBar linear component.
GS1 DataBar Expanded Bar Code Symbol (formerly RSS Expanded)	A bar code that encodes any GS1 Identification Key plus Attribute data, such as weight and “best before” date, in a linear symbol that can be scanned omnidirectionally by suitably programmed Point-of-Sale scanners.
GS1 DataBar Expanded Stacked Bar Code symbol (formerly RSS Expanded Stacked)	A bar code symbol that is a variation of the GS1 DataBar Expanded Bar Code Symbol that is stacked in multiple rows and is used when the normal symbol would be too wide for the application.
GS1 DataBar Limited Bar Code Symbol	A bar code that encodes any GTIN with a leading digit of zero or Indicator digit of one in a linear symbol; for use on small items that will not be scanned at the Point-of-Sale.
GS1 DataBar Omnidirectional (formerly RSS-14)	The members of the GS1 DataBar Symbology family designed to be read in segments by omnidirectional scanners at retail POS: GS1 DataBar Omnidirectional; GS1 DataBar Stacked Omnidirectional; GS1 DataBar Expanded; GS1 DataBar Expanded Stacked.
GS1 Identification Key	A numeric or alphanumeric data field defined by GS1 to ensure the global, unambiguous uniqueness of the identifier in the open demand or supply chain.
GS1 Identification Keys	A globally managed system of numbering used by all GS1 Business Units to identify trade items, logistic units, locations, legal entities, assets, service relationships, and more. The Keys are built by combining GS1 member company identifiers (GS1 Company Prefix) with standards based rules for allocating reference numbers.
GS1 Member Organisation	A member of GS1 that is responsible for administering the GS1 System in its country (or assigned area). This task includes, but is not restricted to, ensuring brand owners make correct use of the GS1 System, have access to education, training, promotion and implementation support and have access to play an active role in GSMP.
GS1 Prefix	A number with two or more digits, administered by the GS1 Global Office that is allocated to GS1 Member Organisations or for Restricted Circulation Numbers.
GS1 System	The specifications, standards, and guidelines administered by GS1.
GS1-128 Symbology	A subset of Code 128 that is utilised exclusively for GS1 System data structures.
GS1-8 Prefix	A one-, two-, or three-digit index number, administered by GS1, denoting the area of distribution of trade items identified by a GTIN-8 or a number used in internal application(see RCN-8).
GTIN-8	The 8-digit GS1 Identification Key composed of a GS1-8 Prefix, Item Reference, and Check Digit used to identify trade items.

GTIN-12	The 12-digit GS1 Identification Key composed of a U.P.C. Company Prefix, Item Reference, and Check Digit used to identify trade items.
GTIN-13	The 13-digit GS1 Identification Key composed of a GS1 Company Prefix, Item Reference, and Check Digit used to identify trade items.
GTIN-14	The 14-digit GS1 Identification Key composed of an Indicator digit (1-9), GS1 Company Prefix, Item Reference, and Check Digit used to identify trade items.
Guard Bar Pattern	An auxiliary pattern of bars and spaces corresponding to start or stop patterns in bar code symbologies, and serving to separate the two halves of EAN-8, EAN-13, and UPC-A Symbols.
Human Readable Interpretation	Characters that can be read by persons, such as letters and numbers, as opposed to symbol characters within bar codes, which are read by machines.
human translation	Text designed to support manual operations and to facilitate key entry in menu driven systems. Data titles and data content are included.
Indicator	A digit from 1 to 9 in the leftmost position of the GTIN-14.
Interleaved 2 of 5 Symbology	Bar code symbology used for the ITF-14 Bar Code .
ITF-14 Bar Code Symbol	ITF-14 (A subset of Interleaved 2-of-5) Bar Codes carry GTINs only on trade items that are not expected to pass through the Point-of-Sale.
Magnification	Different sizes of bar codes based on a nominal size and a fixed aspect ratio; stated as a percentage or decimal equivalent of a nominal size.
Module	The narrowest nominal width unit of measure in a bar code. In certain symbologies, element widths may be specified as multiples of one module. Equivalent to X-dimension.
Modulo 10	Modulo 10 creates a Check Digit according to the Modulo 10 algorithm specified in the <i>GS1 General Specifications</i> .
Modulo 103 GS1-128 Symbol Check Character	A number which results from a modulo calculation that is encoded in the GS1-128 Bar code as a self-checking symbol character. It is created automatically by software as a symbol overhead character and is not expressed in the Human Readable Interpretation.
Point-of-Sale (POS)	Refers to the retail checkout where bar code symbols are normally scanned.
Primary bar code	The bar code containing the identification number of the item (e.g. GTIN [®] , SSCC, etc.). Used to determine the placement of any additional bar code information.
Quiet Zone	A clear space which precedes the Start Character of a bar code and follows the Stop Character. Formerly referred to as "Clear Area" or "Light Margin."
Quiet Zone Indicator	A greater than (>) or less than (<) character, printed in the human readable field of the bar code, with the tip aligned with the outer edge of the Quiet Zone.
Retailer Zero-Suppression Code	A group of 4,500 ID numbers (separate from Local Assigned Codes), that enable the use of UPC-E Bar Codes in a closed system environment (not for open supply chain applications).
scanner	An electronic device to read bar codes and convert them into electrical signals understandable by a computer device.
Separator Character	Function Code 1 used to separate certain concatenated Element Strings, dependent on their positioning in the GS1 Bar codes.
Serial Reference	A component of the Serial Shipping Container Code (SSCC) assigned by the brand owner to create a unique SSCC.
Serial Shipping Container Code	The GS1 Identification Key used to identify logistics units. The key comprised of an Extension digit, GS1 Company Prefix, Serial Reference, and Check Digit.

special characters	Special characters that are designated by the symbology specification.
substrate	The material on which a bar code symbol is printed.
supplier	The party that produces, provides, or furnishes an item or service.
symbol	The combination of symbol characters and features required by a particular symbology, including Quiet Zone, Start and Stop Characters, data characters, and other auxiliary patterns, which together form a complete scannable entity; an instance of a symbology and a data structure.
symbol character	A group of bars and spaces in a symbol that is decoded as a single unit. It may represent an individual digit, letter, punctuation mark, control indicator, or multiple data characters.
Symbol Check Character	A symbol character or set of bar/space patterns included within a GS1-128 or GS1 DataBar Symbol, the value of which is used by the bar code reader for the purpose of performing a mathematical check to ensure the accuracy of the scanned data. It is not shown in Human Readable Interpretation. It is not input to the bar code printer and is not transmitted by the bar code reader.
Symbol Contrast	An ISO/IEC 15416 parameter that measures the difference between the largest and smallest reflectance values in a Scan Reflectance Profile (SRP).
symbology	A defined method of representing numeric or alphabetic characters in a bar code; a type of bar code.
symbology element	A character or characters in a bar code used to define the integrity and processing of the symbol itself (e.g., start and stop patterns). These elements are symbology overhead and are not part of the data conveyed by the bar code.
Symbology identifier	A sequence of characters generated by the decoder (and prefixed to the decoded data transmitted by the decoder) that identifies the symbology from which the data has been decoded.
trade item	Any item (product or service) upon which there is a need to retrieve pre-defined information and that may be priced, or ordered, or invoiced at any point in any supply chain.
truncation	Printing a symbol shorter than the symbology specification's minimum height recommendations. Truncation can make the symbol difficult for an operator to scan.
U.P.C. Company Prefix	A special representation of a GS1 Company Prefix constructed from a U.P.C. Prefix and a Company Number. The U.P.C. Company Prefix is only used to create GTIN-12, Coupon-12, RCN-12 and VMN-12, which are encoded in a UPC-A Bar Code Symbol.
U.P.C. Prefix	A special representation of the GS1 Prefixes '00 – 09' with the leading zero removed. Used when representing the GTIN-12, Coupon-12, RCN-12 and VMN-12 in a UPC-A Bar Code Symbol.
UPC-A Bar Code Symbol	A bar code of the EAN/UPC Symbology that encodes GTIN-12, Coupon-12, RCN-12, and VMN-12.
UPC-E Bar Code Symbol	A bar code of the EAN/UPC Symbology representing a GTIN-12 in six explicitly encoded digits using zero-suppression techniques.
wide-to-narrow ratio	The ratio between the wide elements and the narrow elements in a bar code symbology, such as ITF-14, which has two different element widths.
X-dimension	The specified width of the narrow element in a bar code symbol.

Legacy (Retired) Terms

GS1 was established in 2005 by the bringing together of EAN International and the Uniform Code Council. This led to the re-branding of many aspects of the GS1 System (formerly EAN.UCC

System) and any replaced or retired terms are maintained in the *GS1 General Specifications* for a minimum of five years. The following table summarises the key legacy and current terms.

Legacy Term	Current Term
EAN	GS1
EAN International	GS1 Global Office
EAN Member Organisation	GS1 Member Organisation
EAN/UCC-8 Data Structure	GTIN-8
EAN/UCC-8 Identification Number	GTIN-8
EAN/UCC-13 Data Structure	GTIN-13, Coupon-13, RCN-13, and VMN-13
EAN/UCC-13 Identification Number	GTIN-13, GLN, GDTI, Coupon-13, RCN-13, and VMN-13
EAN/UCC-14 Data Structure	GTIN-14
EAN/UCC-14 Identification Number	GTIN-14
print gain/loss	bar gain/loss
UCC	GS1 US
UCC Company Prefix	U.P.C. Company Prefix
UCC Prefix	U.P.C. Prefix
UCC-12 Data Structure	See GTIN-12, GDTI-12, Coupon -12, RCN-12, and VMN-12
UCC-12 Identification Number	See GTIN-12, GDTI-12, Coupon -12, RCN-12, and VMN-12
Uniform Code Council, Inc	GS1 US